



NRL/MR/6170--04-8763

Replacement of Chromium Electroplating on C-2, E-2, P-3 and C-130 Propeller Hub Components Using HVOF Thermal Spray Coatings

BRUCE D. SARTWELL

*Surface Chemistry Branch,
Chemistry Division*

KEITH O. LEGG

*Rowan Technology Group,
Libertyville, IL*

AARON NARDI

*Hamilton Sundstrand
Windsor Locks, CT*

ROBERT KESTLER

*Naval Aviation Depot
Cherry Point, NC*

WARREN ASSINK

*CAir Force Materiel Command
Dayton, OH*

JERRY SCHELL

*GE Aircraft Engines
Cincinnati, OH*

March 31, 2004

REPORT DOCUMENTATION PAGE

Form Approved
OMB No. 0704-0188

Public reporting burden for this collection of information is estimated to average 1 hour per response, including the time for reviewing instructions, searching existing data sources, gathering and maintaining the data needed, and completing and reviewing this collection of information. Send comments regarding this burden estimate or any other aspect of this collection of information, including suggestions for reducing this burden to Department of Defense, Washington Headquarters Services, Directorate for Information Operations and Reports (0704-0188), 1215 Jefferson Davis Highway, Suite 1204, Arlington, VA 22202-4302. Respondents should be aware that notwithstanding any other provision of law, no person shall be subject to any penalty for failing to comply with a collection of information if it does not display a currently valid OMB control number. **PLEASE DO NOT RETURN YOUR FORM TO THE ABOVE ADDRESS.**

1. REPORT DATE (DD-MM-YYYY) March 31, 2004			2. REPORT TYPE Final		3. DATES COVERED (From - To)	
4. TITLE AND SUBTITLE Replacement of Chromium Electroplating on C-2, E-2, P-3, and C-130 Propeller Hub Components Using HVOF Thermal Spray Coatings					5a. CONTRACT NUMBER	
					5b. GRANT NUMBER	
					5c. PROGRAM ELEMENT NUMBER	
6. AUTHOR(S) Bruce D. Sartwell, Keith O. Legg, ¹ Aaron Nardi, ² Robert Kestler, ³ Warren Assink, ⁴ and Jerry Schell ⁵					5d. PROJECT NUMBER	
					5e. TASK NUMBER	
					5f. WORK UNIT NUMBER	
7. PERFORMING ORGANIZATION NAME(S) AND ADDRESS(ES) Naval Research Laboratory, Code 6170 4555 Overlook Avenue, SW Washington, DC 20375-5320					8. PERFORMING ORGANIZATION REPORT NUMBER NRL/MR/6170-04-8763	
9. SPONSORING / MONITORING AGENCY NAME(S) AND ADDRESS(ES) Environmental Security Technology Certification Program 901 North Stuart Street, Suite 303 Arlington, VA 22203					10. SPONSOR / MONITOR'S ACRONYM(S) ESTCP	
					11. SPONSOR / MONITOR'S REPORT NUMBER(S) EPP-9922-FR	
12. DISTRIBUTION / AVAILABILITY STATEMENT Approved for public release; distribution is unlimited.						
13. SUPPLEMENTARY NOTES ¹ Rowan Technology Group, Libertyville, IL ² Hamilton Sundstrand, Windsor Locks, CT ³ Naval Aviation Depot, Cherry Point, NC ⁴ Air Force Materiel Command, Dayton, OH ⁵ GE Aircraft Engines, Cincinnati, OH						
14. ABSTRACT Hard chromium electroplating is extensively used by aircraft manufacturers and military maintenance depots to provide wear and/or corrosion resistance or to restore dimensional tolerance to components. However, chrome plating utilizes hexavalent chromium, which is a highly toxic carcinogen, and increasingly stringent environmental and worker-safety regulations are making chrome plating more expensive for the DoD. This document constitutes the final report on a project to qualify high-velocity oxygen-fuel (HVOF) thermal spray coatings as a replacement for hard chrome plating on propeller hub components from various military aircraft. Extensive fatigue, wear, and corrosion test results comparing HVOF WC/17Co, WC/10Co4Cr, and Tribaloy 800 coatings against hard chrome are presented. In general, the performance of the HVOF coatings was superior to hard chrome. A rig test on a P-3 low-pitch-stop lever sleeve coated with WC/17Co showed acceptable performance. A cost/benefit analysis conducted for a military repair depot that overhauls propeller hub components showed a slight cost increase associated with use of the HVOF coatings.						
15. SUBJECT TERMS Thermal spray; HVOF thermal spray; WC/Co coatings; WC/CoCr coatings; Hard chrome plating; Propeller hubs; Fatigue; Wear; Corrosion						
16. SECURITY CLASSIFICATION OF:			17. LIMITATION OF ABSTRACT UL	18. NUMBER OF PAGES 104	19a. NAME OF RESPONSIBLE PERSON Bruce D. Sartwell	
a. REPORT Unclassified	b. ABSTRACT Unclassified	c. THIS PAGE Unclassified			19b. TELEPHONE NUMBER (include area code) (202) 767-0722	

TABLE OF CONTENTS

Table of Contents	iii
List of Figures	v
List of Tables	vii
List of Acronyms	viii
Acknowledgments.....	ix
1. Background.....	1
1.1. References	5
2. Technology Description.....	7
2.1. Technology Development and Application.....	7
2.2. Process Description.....	8
2.3. Previous Testing of the Technology.....	11
2.4. Advantages and Limitations of the Technology	12
2.5. References	12
3. Materials and Component Rig Testing	13
3.1. General Program Summary	13
3.2. Overall Conclusions	13
3.3. Corrosion.....	14
3.3.1. Introduction.....	14
3.3.2. Test Specimens	14
3.3.2.1. Test Procedure.....	15
3.3.3. Test Results.....	16
3.3.4. Discussion.....	16
3.3.5. Conclusions.....	16
3.3.6. Recommendations.....	17
3.4. Fatigue.....	22
3.4.1. Introduction.....	22
3.4.2. Specimens	22
3.4.3. Test Procedure	22
3.4.4. Testing Conditions	24
3.4.5. Results.....	25
3.4.6. Discussion.....	26

3.4.7.	Conclusions.....	29
3.5.	Wear	38
3.5.1.	Introduction.....	38
3.5.2.	Specimens	38
3.5.2.1.	Test Procedure.....	39
3.5.3.	Results.....	42
3.5.3.1.	Steel Counter-Face Testing.....	42
3.5.3.2.	Copper Counter-Face Specimens.....	43
3.5.3.3.	Viton Counter-Face Specimens.....	44
3.5.3.4.	15% Glass-Filled PTFE Counter-Faces	44
3.5.4.	Discussion.....	45
3.5.5.	General Conclusions	46
3.5.6.	Recommendations.....	46
3.6.	Toxicity Characteristic Leaching Procedure (TCLP).....	70
3.6.1.	Introduction.....	70
3.6.2.	Findings.....	70
3.6.3.	Discussion.....	70
3.7.	Component Testing	70
3.7.1.	Introduction.....	70
3.7.2.	Test Procedure	71
3.7.3.	Results.....	71
3.7.4.	Conclusions.....	72
3.7.5.	Recommendations.....	72
3.8.	References	75
4.	Cost Benefit Analysis	77
4.1.	Introduction	77
4.2.	Approach.....	78
4.3.	Data and Assumptions.....	80
4.3.1.	Data Provided by Repair/Overhaul Facility.....	81
4.3.1.1.	Current Hard Chrome Electroplating Operations.....	81
4.3.1.2.	Transitioning from Hard Chrome Electroplating to HVOF WCCo.....	81
4.3.2.	Assumptions About Current and Future Operations – Base Scenario.....	82
4.3.3.	Additional Assumptions for Scenario 2 [More Stringent OSHA Regulations	

on Chrome Exposure Enacted and Improved Durability/Performance of HVOF WC/Co Compared to Electroplated Hard Chrome]	84
4.3.4. Additional Assumptions for Scenario 3 (Scenario 2 plus Benefits from Decreased Turn-Around Time)	86
4.4. Annual Operating Cost Avoidance	86
4.5. Summary and Recommendations	88
4.6. References	89
4.7. Other Sources of Information	89
5. Summary and Implementation of HVOF Technology	91
5.1. Performance of HVOF vs. EHC Coatings	91
5.2. Cost of HVOF vs. EHC Coatings	91
5.3. Standards and Specifications	92
5.4. Implementation of HVOF Thermal Spray Coatings in Manufacturing and Repair/Overhaul Operations	93
5.5. References	94

LIST OF FIGURES

Figure 2-1. Schematic of HVOF Gun and Process (Sulzer Metco DiamondJet)	7
Figure 2-2. HVOF Spray of Landing Gear Inner Cylinder	8
Figure 3-1. Flat Panel Corrosion Specimen	18
Figure 3-2. 0.001”-Thick WC/Co HVOF	19
Figure 3-3. 0.001”-Thick Nickel Plate	19
Figure 3-4. 0.001”-Thick Tribaloy T-800 HVOF	20
Figure 3-5. 0.001”-Thick WC/CoCr HVOF	20
Figure 3-6. WC/Co Coated Panel, Top Surface Coated	21
Figure 3-7. WC/Co Coated Panel, Top Surface Coated, Bottom Surface Glass Bead Peened	21
Figure 3-8. Tension/Tension Fatigue Specimen - Smooth	30
Figure 3-9. Tension/Tension Fatigue Specimen – Notched	31
Figure 3-10. Peened Fatigue Data, R = 0.1	32
Figure 3-11. S/N Curves for Non-Peened Coatings and Notched Specimens	33
Figure 3-12. S/N Curves for 0.003” T-800 on 4340 Steel, R = 0.1	34
Figure 3-13. S/N Curves for 0.010”-thick T-800 on 4340 Steel, R = 0.1	35

Figure 3-14. S/N Curves for 0.015”-thick T-800 on 4340 Steel, R = 0.1	36
Figure 3-15. White Light of EHC Coated Specimen Showing Cracks Created By Machining Process	37
Figure 3-16. Counter-Face Wear Specimen.....	47
Figure 3-17. Coated Panel Wear Specimen	47
Figure 3-18. Wear Test Specimen Assembly	48
Figure 3-19. Wear Test Fixture in Test Frame	49
Figure 3-20. Wear Test Assembly With Test Specimens.....	50
Figure 3-21. Steel Wear Rate Comparison	51
Figure 3-22. Panel Wear From Steel Specimens	52
Figure 3-23. EHC Dithering in Contaminated Oil With Steel Counter-faces	53
Figure 3-24. WC/Co Dithering in Contaminated Oil with Steel Counter-faces.....	53
Figure 3-25. T-800 Dithering in Contaminated Oil With Steel Counter-Faces.....	54
Figure 3-26. Copper Wear Rate Comparison	55
Figure 3-27. Panel Wear From Copper Specimens	56
Figure 3-28. Panel Wear Rate Coefficient Against Copper Counter-Faces	57
Figure 3-29. EHC Reciprocating Against Copper Counter-Faces.....	58
Figure 3-30. WC/Co Reciprocating Against Copper Counter-Faces.....	58
Figure 3-31. T-800 Reciprocating Against Copper Counter-Faces.....	58
Figure 3-32. Viton Wear Rate Comparison	59
Figure 3-33. Panel Wear From Viton Specimens	60
Figure 3-34. PTFE Wear Rate Comparison.....	61
Figure 3-35. Panel Wear From PTFE Specimens.....	62
Figure 3-36. Electrolytic Hard Nickel Plate Dithering Against 15% Glass Filled PTFE Counter-Faces	63
Figure 3-37. WC/CoCr HVOF Coating Dithering Against 15% Glass Filled PTFE Counter-Faces	63
Figure 3-38. Friction Coefficients.....	64
Figure 3-39. PTFE Friction Coefficient Comparison	65
Figure 3-40. Electrolytic Hard Chrome, 500X Magnification.....	66
Figure 3-41. HVOF WC/Co, 500X Magnification	66
Figure 3-42. HVOF Tribaloy T-800, 500X Magnification.....	67
Figure 3-43. HVOF WC/CoCr, 500X Magnification	67

Figure 3-44. Electrolytic Hard Nickel Plate, 500X Magnification.....	68
Figure 3-45. Electrolytic Hard Nickel Plate, 500X Magnification, Etched With 50% Nitric / 50% Acetic Acid for 1-2 Seconds	68
Figure 3-46. 300 Gram Vickers Hardness Impressions on HVOF WC/Co.....	69
Figure 3-47. 300 Gram Vickers Hardness Impressions on HVOF Tribaloy T-800.....	69
Figure 3-48. Low-Pitch-Stop Sleeve Testing Fixture	73
Figure 3-49. Low-Pitch-Stop Sleeve Testing Fixture Schematic	73
Figure 3-50. Low-Pitch-Stop Sleeves and Piston Rings After Testing	74
Figure 4-1. Process Flow of Hard-Chrome Electroplating.....	78
Figure 4-2. Process Flow of HVOF for Applying WC/Co	80

LIST OF TABLES

Table 1-1. HVOF Thermal Spraying Summary.....	4
Table 1-2. HVOF Thermal Spraying Summary: System Applications.	4
Table 2-1 . Optimized Deposition Conditions for WC/17Co - DJ 2600 and JP 5000 HVOF Guns	10
Table 2-2 . Advantages and Limitations of HVOF as a Chrome Replacement.....	12
Table 3-1 . Summary of Samples As-Plated or HVOF-Coated.....	15
Table 3-2 . Summary of Samples Following Surface Grinding (0.002” Type Stock Removal).....	15
Table 3-3 . Fatigue Test Matrix	24
Table 3-4 . Summary of Fatigue Data Figures.....	25
Table 3-5 . Statistical Analysis of Fatigue Strengths.....	28
Table 3-6 . Wear Test Matrix.....	40
Table 3-7 . TCLP Test Results.....	70
Table 3-8 . Dimensional Data for Low-Pitch-Stop Sleeve and Piston Ring During Testing.....	72
Table 4-1 . Estimated Annual Operating Cost Avoidance.....	87

LIST OF ACRONYMS

ALC	air logistics center
AMS	Aerospace Materials Specification
ANSI	American National Standards Institute
ASTM	American Society for Testing and Materials
CBA	cost benefit analysis
CFR	Code of Federal Regulations
DARPA	Defense Advanced Research Projects Agency
DOD	Department of Defense
DOE	design of experiment
ECAM	Environmental Cost Accounting Methodology
EHC	electrolytic hard chrome
EHN	electrolytic hard nickel
EPA	Environmental Protection Agency
ESOH	environmental, safety and occupational health
ESTCP	Environmental Security Technology Certification Program
GEAE	GE Aircraft Engines
gph	gallons per hour
GTE	gas turbine engine
HCAT	Hard Chrome Alternatives Team
HS	Hamilton Sundstrand
HVOF	high-velocity oxygen-fuel
IARC	International Agency for Research on Cancer
ID	internal diameter
JG-PP	Joint Group on Pollution Prevention
JTP	Joint Test Protocol
JTR	Joint Test Report
NADEP-CP	Naval Aviation Depot Cherry Point
NRL	Naval Research Laboratory
OEM	original equipment manufacturer
OSHA	Occupational Safety and Health Administration
PEL	permissible exposure limit
psi	pounds per square inch
PTFE	Polytetrafluoroethylene
PVD	physical vapor deposition
SAE	Society of Automotive and Aerospace Engineers
scfh	standard cubic feet per hour
TAT	turn-around time
TBO	time between overhaul
TCLP	Toxicity Characteristic Leaching Procedure
TWA	time-weighted average
WR-ALC	Warner-Robins Air Logistics Center

ACKNOWLEDGMENTS

The financial and programmatic support of the Department of Defense Environmental Security Technology Certification Program, under the direction of Dr. Jeffrey Marqusee, Director, and Mr. Charles Pellerin, Program Manager for Pollution Prevention, is gratefully acknowledged. In addition, the financial and programmatic support of the Joint Group on Pollution Prevention and the Air Force Materiel Command, coordinated by Ms. Debbie Meredith, is also gratefully acknowledged.

The authors would also like to express thanks to the following individuals who made substantial contributions to the execution of the project:

- Mr. Gene Jeunelot, Air Force Materiel Command
- Mr. James Hager, Warner-Robins Air Logistics Center

This page intentionally left blank.

1. Background

The replacement of hard chrome plating in aircraft manufacturing activities and maintenance depots is a high priority for the U.S. Department of Defense. Hard chrome plating is a technique that has been in commercial production for over 50 years. It is a critical process that is used both for applying hard coatings to a variety of aircraft components in manufacturing operations and for general re-build of worn or corroded components that have been removed from aircraft during overhaul. Chromium plating baths contain chromic acid, in which the chromium is in the hexavalent state, with hexavalent chromium (hex-Cr) being a known carcinogen having a level of toxicity greater than arsenic or cadmium. During operation, chrome plating tanks emit a hex-Cr mist into the air, which must be ducted away and removed by scrubbers. Wastes generated from plating operations must be disposed of as hazardous waste and plating operations must abide by U.S. Environmental Protection Agency (EPA) emissions standards and Occupational Safety and Health Administration (OSHA) permissible exposure limits (PEL).

A significant lowering of the hex-Cr PEL would most likely have a significant cost impact on military and commercial repair facilities. Such a change has been expected for several years but has not yet been issued by OSHA. In anticipation of the change, in 1995 a Navy/Industry task group under the coordination of the Naval Sea Systems Command studied the technical and economic impact of a reduction in the hex-Cr PEL. At the time, a reduction in the 8-hour time-weighted average (TWA) from the existing $100 \mu\text{g}/\text{cm}^3$ to between 0.5 and $5.0 \mu\text{g}/\text{cm}^3$ was being considered. The Navy/Industry task group performed the following tasks:

- Identified the manufacturing and repair operations, materials and processes that are used in Navy ships, aircraft, other weapons systems and facilities where worker exposure to hex-Cr would be expected
- Developed data on current worker exposure levels to hex-Cr using OSHA Method 215
- Estimated the technical and economic impact of the anticipated reductions in hex-Cr exposure on Navy ships, aircraft, other weapons systems and facilities
- Identified future actions required to comply with the anticipated PEL reductions

The following operations were identified as having the potential for exposing workers to hex-Cr:

- Metal cleaning (including abrasive blasting and grinding) of chromate-coated materials
- Electroplating of chromium
- Painting and application of chromate paints and coatings
- Welding, thermal spraying and thermal cutting

The following conclusions were reached by the task group:

- Regulated areas for hex-Cr would have to be created in much greater numbers than have been required for cadmium or lead exposure
- Local exhaust ventilation, which is the presently available engineering control, is

- not completely effective in reducing exposure to below $0.5 \mu\text{g}/\text{cm}^3$ for many operations or even below $5 \mu\text{g}/\text{cm}^3$ in some cases
- The inability of engineering controls to consistently reduce worker exposure below the anticipated PEL levels will significantly increase the use of respirators
 - The costs of reducing the hex-Cr PEL will include costs for training, exposure monitoring, medical surveillance, engineering controls, personal protective equipment, regulated areas, hygiene facilities, housekeeping and maintenance of equipment. There will also be costs due to reduced efficiency of not only the operations involving hex-Cr but adjacent operations and personnel as well.
 - The estimated costs for compliance with a PEL of $0.5 \mu\text{g}/\text{cm}^3$ at Navy facilities include an initial, one-time cost of about \$22,000,000 and annual costs of about \$46,000,000 per year.
 - The estimated costs for compliance with a PEL of $5.0 \mu\text{g}/\text{cm}^3$ at Navy facilities include an initial, one-time cost of about \$3,000,000 and annual costs of about \$5,000,000 per year
 - In addition to the greatly increased cost that would be associated with chrome plating, turnaround times for processing of components would be significantly increased as well, impacting mission readiness.

Although OSHA has delayed issuance of a new hex-Cr PEL, recent studies have clearly shown that there are a significant number of excess deaths at the current PEL of $0.1 \text{ mg}/\text{m}^3$ for hex-Cr emissions in plating facilities. For example, the August 2000 issue of the American Journal of Industrial Medicine contained a report on a study of 2,357 workers over a 30-year period which correlated the incidence of cancer with hex-Cr exposure. An analysis of the study was conducted by the Navy Environmental Health Center and it was their conclusion that the study appeared to support a lowering of the PEL to less than $0.001 \text{ mg}/\text{m}^3$. Although OSHA has not issued a schedule for issuance of a proposed new hex-Cr PEL, it appears clear that ultimately the PEL will have to be lowered.

Previous research and development efforts [1.1, 1.2] had established that high-velocity oxygen-fuel (HVOF) thermal spray coatings are the leading candidates for replacement of hard chrome. Using commercially available thermal spray systems, HVOF thermal spraying can be used to deposit both metal alloy and ceramic/metal (cermet) coatings such as tungsten carbide in a cobalt matrix (WC/Co) that are dense and highly adherent to the base material. They also can be applied in thicknesses in the same range as that currently being used for chrome plating. Although there are a wide number of applications for these coatings, their qualification as an acceptable replacement for hard chrome plating has not been adequately demonstrated, particularly for fatigue-sensitive aircraft components.

The Environmental Security Technology Certification Program (ESTCP) was established as a program of the U. S. Department of Defense (DOD) in December, 1993. The ESTCP, which is managed by the Deputy Under Secretary of Defense for Installations and Environment, demonstrates and validates lab-proven technologies that target the most urgent DOD environmental needs. These technologies provide a return on investment through reduced environmental, safety, and occupational health (ESOH) risks; cost savings; and improved efficiency. The new technologies typically have broad

application both to the DOD sustainment community and industry.

In order to conduct the advanced development work required for qualification of the HVOF coatings, a project entitled, "Tri-Service Dem/Val of Chromium Electroplating Replacements," principally sponsored by ESTCP, was established in March 1996. A project team, designated the Hard Chrome Alternatives Team (HCAT) was established to execute the project. From 1996 to early 1998, the HCAT acquired and installed HVOF thermal spray systems at the Naval Aviation Depot in Cherry Point, North Carolina and the Corpus Christi Army Depot. It also performed some generic fatigue and corrosion testing on HVOF WC/17Co (83 wt% WC particles in a 17 wt% Co matrix) and Tribaloy 400 (60% Co, 28% Mo, 9% Cr, 3% Si) coatings compared to electrolytic hard chrome (EHC) coatings. Substrate materials included 4340 steel, 7075 aluminum alloy, and PH13-8 stainless steel. From a fatigue standpoint the HVOF coatings generally performed better than the EHC coatings (i.e., there was a reduced fatigue debit with respect to the non-coated material for the HVOF coatings compared to the EHC coatings). In B117 salt fog corrosion studies, the performance of the WC/Co was comparable to the EHC, with the Tribaloy 400 slightly worse. In atmospheric corrosion studies, the WC/Co performed substantially better than the EHC, with the Tribaloy 400 comparable to the EHC.

While these studies were valuable, it was realized in early 1998 that because hard chrome plating was being used on such a wide variety of aircraft components, it would be impossible to develop one test plan or conduct one series of tests that would address all materials and component qualification requirements. It was therefore decided to develop separate projects related to categories of aircraft components onto which hard chrome was being used. At the same time, the DOD Joint Group on Pollution Prevention (JG-PP) decided to partner with the HCAT on development and execution of the various projects. JG-PP is chartered by the Joint Logistics Commanders (JLC) to coordinate joint service pollution prevention activities during the acquisition and sustainment of weapons systems. It was jointly determined by the HCAT and JG-PP that the first projects to be executed would be on landing gear and propeller hubs, with projects on hydraulic actuators and helicopter dynamic components to come later. (Note that there is also a fifth project being executed between the HCAT and DOD Propulsion Environmental Working Group on hard chrome replacement on gas turbine engine components.)

Since the technology to be demonstrated and validated as a hard chrome replacement had already been selected (namely HVOF thermal spray), then the first activity for the propeller hub project was the development of the Joint Test Protocol (JTP) which would delineate all of the materials and component testing requirements necessary to qualify the HVOF coatings on propeller hub components for all types of DOD aircraft. Table 1-1 and Table 1-2 summarize the target hazardous material, current process, application, current specifications, and affected defense systems programs (delineated according to the U.S. DOD aviation depot at which the overhaul of the propeller hubs from that aircraft takes place).

Table 1-1. HVOF Thermal Spraying Summary

Target HazMat	Current Process	Application	Current Specifications	Candidate Parts/ Substrates
Hexavalent Chromium	Hard Chromium Electroplating	Rebuilding Worn Components Wear-resistant Coating Corrosion-resistant Coating	DOD-STD-2182 MIL-C-14538C MIL-C-20218F MIL-H-83282 MIL-STD-1501C QQ-C-320B	Hamilton Standard Propeller Hubs

Table 1-2. HVOF Thermal Spraying Summary: System Applications.

Affected Defense System Programs			
<u>NADEP Cherry Point:</u>	<u>Warner-Robins Air Logistics Center</u>	<u>Canadian DND</u>	<u>Coast Guard</u>
C-130	C-130	C-130	C-130
E-2/C-2		P-3	P-3
P-3			

A stakeholder meeting was held at Hamilton Sundstrand in September 1998 to discuss the types of materials testing that would be required and also to explore what avenues were available for component testing. Subsequent discussions and correspondence led to the finalization of the JTP in November 1999 [1.3]. The following were the organizations that contributed to the development of the JTP:

- Naval Air Systems Command
- Navy PEO(A) PMAs 207, 231, and 290
- Naval Aviation Depot Cherry Point
- Air Force C-130 Single Manager (WR-ALC/LBR)
- Air Force Materiel Command
- Warner-Robins Air Logistics Center
- Hamilton Sundstrand
- Naval Research Laboratory

The Propeller Hub JTP was organized in sections, with each devoted to the type of test being conducted. Section 3 of this report, essentially reproducing the Joint Test Report (JTR), provides the results of all of the testing conducted in accordance with the JTP. It is organized into sections based on the type of testing that was performed as follows:

1. Overall program conclusions

2. Corrosion
3. Fatigue
4. Wear
5. Toxicity Characteristic Leaching Procedure (TCLP) on thermal spray powder
6. Low-pitch-stop lever sleeve component test

Another issue related to successful transitioning of the HVOF technology was relative costs compared to hard chrome plating and determining the return-on-investment by implementing the HVOF thermal spray coatings. The results of a detailed cost/benefit analysis are presented in Section 4.

Finally, a review of issues associated with implementation of HVOF thermal spray coatings in repair facilities is presented in Section 5.

1.1. References

- 1.1 "High Velocity Oxy Fuel Final Results Report," Final Report issued by Science Applications International Corporation under Government Contract F09603-90-D2215, Oklahoma City Air Logistics Center, Tinker Air Force Base, May 25, 1994.
- 1.2 "Hard Chrome Coatings: Advanced Technology for Waste Elimination," Final Report issued by Northwestern University, Evanston, IL, under DARPA Contract MDA972-93-1-0006, 1996.
- 1.3 "Joint Test Protocol, Validation of WC/Co, WC/CoCr and Tribaloy 800 HVOF Thermal Spray Coatings as a Replacement for Hard Chrome Plating on C-2/E-2/P-3 and C-130 Propeller Hubs and Low Pitch Stop Sleeve." Prepared by Hard Chrome Alternatives Team for Environmental Security Technology Certification Program, November 1999.

This page intentionally left blank.

2. Technology Description

2.1. Technology Development and Application

Technology background and theory of operation: High-velocity oxygen-fuel (HVOF) is a standard commercial thermal spray process in which a powder of the material to be sprayed is injected into a supersonic flame of a fuel (usually hydrogen, propylene or kerosene). The powder particles are accelerated to high speed and soften in the flame, forming a dense, well-adhered coating on the substrate (see Figure 2-1). The coating material is usually a metal or alloy (such as Tribaloy or stainless steel), or a cermet (such as cobalt-cemented WC/Co). The technology is used to deposit coatings about 0.003” thick on original equipment manufacturer (OEM) parts, and to rebuild worn components by depositing layers up to 0.015” thick.

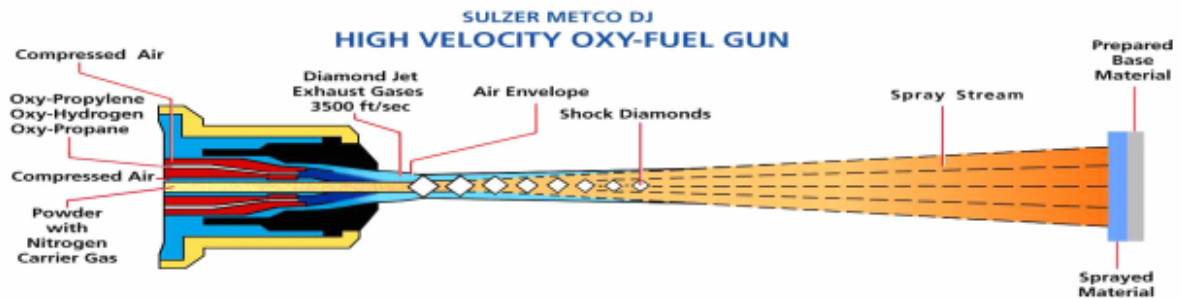

Figure 2-1. Schematic of HVOF Gun and Process (Sulzer Metco DiamondJet)

Applicability: High Velocity Oxygen Fuel (HVOF) was originally developed primarily for gas turbine engine (GTE) applications. The primary thermal spray processes are Flame Spray, Plasma Spray, Arc Spray, HVOF and the recently-developed cold spray. The original high velocity spray technology was the pulsed deposition detonation gun (D-gun) developed by Union Carbide (later Praxair). The quality of the wear and erosion resistant spray coatings produced by this method was much better than the lower speed methods, and continuous flame HVOF was developed as a competitive response.

The original applications for HVOF were wear components in GTEs, such as shafts and bearing journals. As the availability and use of the technology grew, it began to be applied to a wide range of other types of coatings and applications, including a variety of aircraft components such as flap and slat tracks, landing gear and hydraulics for commercial aircraft. It is now being used in many applications outside the aircraft industry, such as industrial rolls and vehicle hydraulics. The original aircraft wear applications, primarily used by Boeing, were for otherwise-intractable spot problems that neither the original alloy nor chrome plate could solve.

The technology can be used to spray a wide variety of alloys and cermets. It is limited for high temperature materials such as oxides, most of which cannot be melted in the flame. The areas to be coated must be accessible to the gun – i.e., they must be line-of-sight.

Material to be Replaced: HVOF coatings are used to replace hard chrome plate

(especially using carbide cermets and high temperature oxidation-resistant Triballoys). The combination of HVOF NiAl with an overlayer carbide is also used to replace the combination sulfamate Ni/hard chrome. HVOF coatings can also be used to replace some hard Ni and electroless Ni coatings on such components as flap tracks and propeller hubs. In the HCAT program the primary application is hard chrome replacement.

2.2. Process Description

Installation and Operation: The HVOF gun can be hand-held and used in an open-fronted booth. However, the supersonic gas stream is extremely loud and requires that the operator use very good ear protection. For this reason the unit is usually installed on a six-axis robot arm in a sound-proof booth, programmed and operated remotely. Most depots already use this type of booth for their existing plasma spray operations. Since the method is frequently used for cylindrical items, the most common arrangement is to rotate the component on a horizontal rotating table and move the gun up and down the axis. This is illustrated in Figure 2-2 which shows the HVOF spraying of a landing gear inner cylinder. A similar setup would be used for the spraying of cylindrical-shaped propeller hub components such as a lever sleeve.



Figure 2-2. HVOF Spray of Landing Gear Inner Cylinder

Facility Design: The installation requires:

- A soundproof booth. Booths are typically 15 feet square, with a separate operator control room, an observation window and a high-volume air handling system drawing air and dust out of the booth through a louvered opening (shown in Figure 2-2).
- Gun and control panel. The gun burns the fuel and oxygen inside its combustion chamber and injects the powder axially into the flame. The gas exits the gun at supersonic speed, while the particles are accelerated to high velocity but usually remain subsonic. The control panel controls the gas flows, cooling water, etc.
- Powder feeder. Powder is typically about 60 μ m in diameter and is held in a powder feeder, which meters the powder to the gun at a steady rate, carried on a gas stream. Two powder feeders are commonly used to permit changeover from one coating to another without interrupting the spraying.
- 6-axis industrial robot and controller. Most installations use an industrial robot to

manipulate the gun and ensure even spraying. The robot is often suspended from above to leave the maximum possible floor space for large items.

- Supply of oxygen. This is frequently a bulk storage container outside the building. Alternatively, bottled gas can be used but, because of the high usage rate of up to 2,000 scfh (see Table 2-1), even a standard 12-bottle setup lasts only a few hours in production.
- Supply of fuel gas or kerosene (bottled or bulk). Hydrogen is the most common fuel, supplied in bulk or in bottles. Praxair (TAFA) guns use kerosene, which is significantly cheaper and less dangerous.
- Dust extractor and bag-house filter system. The air extracted from the booth is laden with overspray – particles that have failed to stick to the surface (often 20-50% of the total sprayed). The air is blown into a standard bag house, often located outside the building, where the dust is removed.
- Dry, oil-free compressed air for cooling the component and gun. Air cooling prevents the components being overheated (temperatures must be kept below about 400°F for most high strength steels).
- Water cooling for gun. Not all guns are water cooled, but most are.

The facility must be capable of supplying the material pressures and flows of Table 2-1. Standard commercial equipment currently in service already meets these requirements. Equipment vendors are able to supply turnkey systems.

Performance: From Table 2-1, HVOF guns deliver about 4-5 kg per hour, of which 65% typically enters the coating, for a coating rate of about 3 kg/hour. For a common 0.010"-thick WC/Co rebuild coating (which will be sprayed to a thickness of 0.013"-0.015"), an HVOF gun can deposit about 900 in²/hr. This permits the coating of the outside diameter of a 25"-long, 4"-diameter cylinder in about 30 minutes, compared with about 12 hours for chrome plating.

Table 2-1 . Optimized Deposition Conditions for WC/17Co - DJ 2600 and JP 5000 HVOF Guns

Equipment	Gun Console Powder feeder	Model 2600 hybrid gun Model DJC Model DJP powder feeder	Model 5220 gun with 8" nozzle Model 5120 Model 5500 powder feeder
Powder feed	Powder Powder Feed Rate: Powder Carrier Gas Carrier gas pressure Flow rate	Diamalloy 2005 8.5 lb/hr Nitrogen 148 psi 28 scfh	Stark Amperit 526.062 80 gm/min (325 rpm, 6 pitch feeder screw) Argon 50 psi 15 scfh
Combustion Gases	Fuel Console supply pressure Gun supply pressure Flow rate Oxidizer Pressure Mass flow	Hydrogen 135 psi 1229 scfh Oxygen 148 psi 412 scfh	Kerosene, Type 1-K 162-168 psi 121-123 psi 5.0 gph Oxygen 138-140 psi 2000 scfh
Gun Compressed Air	Pressure Mass flow	105 psi 920 scfh	
Gun Cooling Water Flow	Flow rate Water Temperature to Gun:	5.3-5.7 gph (factory set) 65-80°F typical (ground water, temp varies)	8.3-8.7 gph 64-72°F
Specimen Rotation		2,336 rpm for round bars (0.25" dia.) – 1835 in/min surface speed	600 rpm for round bars (0.25" diam.); 144 rpm for rectangular bars (at 6.63" diam.)
Gun Traverse Speed		400 linear in/min for round bars	70 in/min for round bars
Spray Distance		11.5"	18"
Cooling Air	Pressure Location	90-110 psi 2 stationary nozzle tips at 6" pointed at coating area	90-110 psi 2 gun-mounted air jets at 14"; 1 stationary air jet at 4-6" pointed at coating area

Specifications: The following specifications and standards apply to HVOF coatings:

- Prior to the HCAT program, the only aerospace specifications were those issued by OEMs such as Boeing, whose BAC 5851 thermal spray specification, supported by BMS 10-67G powder specification, is still one of the most quoted standards
- Aerospace Materials Specification (AMS) 2447 was developed with the assistance of the HCAT team and issued by SAE in 1998. It is now a widely used standard in the aerospace industry.
- In order to provide specifications for spraying high strength aircraft steels at depots and vendors, HCAT has worked through Society of Automotive and Aerospace Engineers (SAE) to promulgate several standards:
 - AMS 2448, issued in 2003, is a specification for HVOF spraying of high strength steel.
 - AMS 7881 and AMS 7882 are powder specifications that support AMS 2448.
 - An AMS standard for grinding of HVOF coatings will be issued in a few months.

Training: Just as plating shops typically have several personnel who handle masking, racking, demasking, etc., it is common for HVOF shops to have 3 or 4 technicians dedicated to masking and spraying. HVOF training is essential and is usually provided by equipment vendors such as Praxair and Sulzer Metco. Training is also available through the Thermal Spray Society. Depot personnel taking part in the HCAT program have been trained by Jerry Schell, thermal spray coatings expert at GE Aircraft Engines. Since thermal spray is a more complex technology than electroplating, plating line personnel cannot be transferred successfully to an HVOF shop without extensive retraining.

Health and Safety: The process does not produce air emissions or toxic wastes. Co powder is an International Agency for Research on Cancer (IARC) Group 2B material, which means that “The agent (mixture) is possibly carcinogenic to humans”, whereas Cr^{6+} is an IARC Group 1 material, “Known to be carcinogenic to humans”. However, the OSHA PEL for Co (8hr TWA) of $0.1 \text{ mg}(\text{Co})/\text{m}^3$, is lower than the $1 \text{ mg}(\text{Cr})/\text{m}^3$ for metallic chrome, and is the same as the $0.1 \text{ mg}(\text{Cr})/\text{m}^3$ for Cr^{6+} . Unlike chrome plating, the Co is not emitted into the air. Excess Co-containing powder is drawn from the spray booth and captured in the bag house. Nevertheless personnel should wear a dust respirator when handling the powder, working in the booth, or grinding the coating. While the powders are usually about $60\mu\text{m}$ in diameter, they can break apart on impact, producing $10\mu\text{m}$ or smaller particles. The American Welding Society recommends the use of a respirator complying with American National Standards Institute (ANSI) Z88.2

Ease of Operation: Since in commercial systems the entire system is programmable, including the gun control and robot, it is generally easy to operate. The operator must create masking (usually shim stock shadow masks) and must develop the correct spray parameters and gun motions. While vendors supply standard operating conditions for different materials, these may have to be optimized experimentally for new materials and powders, and must be adjusted for different components to ensure proper coating speed and gun traverse rate. Small diameter components, for example, must be rotated faster than large ones to maintain the same deposition rate and coating structure. In this respect operating an HVOF system is considerably more complex than electroplating.

2.3. Previous Testing of the Technology

Prior to the HCAT program, HVOF technology had been successfully used by Boeing for a number of years for their commercial aircraft and by General Electric Aircraft Engines (GEAE) for GTEs. In the period 1993-1996 Keith Legg, Bruce Sartwell, GEAE, Cummins Diesel, and Corpus Christi Army Depot carried out an evaluation of chrome alternatives under the sponsorship of the Defense Advanced Research Projects Agency (DARPA). The program evaluated HVOF, physical vapor deposition (PVD) and laser cladding, and concluded that HVOF was the best overall alternative for use in depots and most OEM aircraft applications [2.1]. At the beginning of the HCAT program, Lufthansa successfully completed flight tests of HVOF coatings on commercial landing gear and Delta began to carry out similar flight tests.

2.4. Advantages and Limitations of the Technology

Replacing hard chrome plating is a great deal more complex than simply putting down a hard coating. The alternative must not only work technically, but it must fit with the entire life cycle of use and maintenance, and it must be a reasonable, mature technology for depot use. The advantages and limitations of HVOF are summarized in Table 2-2.

Table 2-2 . Advantages and Limitations of HVOF as a Chrome Replacement

Advantages/strengths	Disadvantages/limitations
Technical:	
Higher hardness, better wear resistance, longer overhaul cycle, less frequent replacement	Brittle, low strain-to-failure – can spall at high load. Issue primarily for carrier-based aircraft
Better fatigue, corrosion, embrittlement	Line-of-sight. Cannot coat IDs
Material can be adjusted to match service requirements	More complex than electroplating. Requires careful quality control
Depot and OEM fit:	
Most depots already have thermal spray expertise and equipment	WC/Co requires diamond grinding wheel. Only HVOF alloys can be plunge ground
Can coat large areas quickly	
Can be chemically stripped	
Many commercial vendors	
Environmental:	
No air emissions, no high volume rinse water	Co toxicity

2.5. References

- 2.1 “Hard Chrome Coatings: Advanced Technology for Waste Elimination,” Final Report issued by Northwestern University, Evanston, IL, under DARPA Contract MDA972-93-1-0006, 1996.

3. Materials and Component Rig Testing

The testing included fatigue, corrosion and wear testing of specimens coated with three candidate HVOF coatings and electrolytic hard chromium (EHC). The tests were designed to evaluate the durability of the coating and its effect on the fatigue strength of the base material under simulated operating conditions. The three HVOF coatings under consideration were Tribaloy T-800, WC/17CO and WC/CoCr. A Toxicity Characteristic Leaching Procedure (TCLP) test was also run under this program. Its purpose was to determine whether the coatings or the coating powders were considered hazardous waste.

3.1. General Program Summary

The specific propeller components covered under this effort were the 54H60 and 54460 Propeller Hub (tailshaft), the 54H60 and 54460 Low-Pitch-Stop Lever Sleeve, and the 54460 Propeller Hub (rocker land) used on the C-130 Hercules transport, the E-2 Hawkeye and the P-3 Orion anti-submarine aircraft. The Navy depot team members added the evaluation of the hub rocker land later in the program to facilitate replacement of the current electrolytic hard nickel (EHN) plate repair. Each of the component coating surfaces has line-of-sight access and is capable of being sprayed with a spray angle between 45° and 90°, making all of them ideal candidates for the HVOF process. All components are manufactured from either AISI 4340 or 4350 steels with hardness values of 40-44 on the Rockwell C scale. The HCAT Team published a Joint Test Protocol (JTP) [3.1] that defined the testing to be performed and the agreed pass/fail criteria. In general, a coating would be considered an acceptable alternate if its performance was equal to or better than the hard chrome. Testing included fatigue, wear, corrosion, TCLP and sub-assembly component testing.

3.2. Overall Conclusions

Based on the test results, the WC/Co coating exhibited superior fatigue and wear properties compared to EHC and is considered a suitable replacement for chrome in the repair of the low-pitch-stop lever sleeve and hub tail shaft on 54H60 and 54460 propellers. The WC/CoCr is also considered an acceptable replacement for EHN currently used to repair the rocker lands of the 54460 hubs. Prior to their approval for use on flight hardware, however, it is recommended that further testing of coating adhesion in a compressive fatigue environment be completed. Though not part of the original test protocol, this testing will investigate coating delamination issues raised by Orenda Aerospace Corporation, Ontario, Canada while testing R = -1 fatigue specimens. A test program to evaluate compressive fatigue has been developed and is currently underway at Hamilton Sundstrand (HS). At the conclusion of the testing, the coating process developed under this program by the supplier is considered acceptable for use.

The endurance of HVOF coatings and their substrates are highly dependent on a number of factors controlled during the coating process i.e., powder feed rate, temperature, velocity, gun-type, etc. Coating residual stress is recognized as a key property of the coating that directly affects the performance. Under this program, HS worked with a single supplier to spray all specimens. To validate coatings applied by other sources, a correlation must be made of the residual stress attained on the wear and fatigue

specimens, to the Almen strips collected at the time of spraying, to actual sprayed parts. It would be prudent at this juncture to develop a methodology for evaluating and controlling residual stress of thermal spray coatings for all fatigue critical parts.

3.3. Corrosion

3.3.1. Introduction

In addition to the elimination of hard chrome plating from the depots, the Navy requested that the HCAT team investigate the replacement of hard nickel plating used on the 54460 Hub rocker lands. This area of the hub arm bore is a sealing surface for an O-ring energized cap seal. The rocker land, as the name implies, is exposed to a “rocking motion” from the blade seal due to aerodynamic loading of the blade. The cap is made from 15% glass filled polytetrafluoroethylene (PTFE) per HS1401 Grade A. Hard nickel electroplate is applied to this diameter per QQ-N-290, CL. 2, with a minimum Vickers hardness of 500 and a maximum compressive stress of 10,000 psi, in order to repair wear damage encountered in service. WC/Co, WC/CoCr and Tribaloy T-800 thermal spray coatings were evaluated as possible alternatives. WC/CoCr HVOF coating was included in this series due to the reported improved corrosion characteristics over WC/Co. Corrosion resistance is preferred in this application since the rocker land is not bathed in oil, as are the other internal components of the hub and low-pitch-stop, making it vulnerable to environmental attack.

Corrosion testing was performed to compare the level of protection afforded by the HVOF coatings on the low-alloy steel hub material in a corrosive environment. Electroplated nickel was evaluated as the baseline. Test panels were prepared with coating thicknesses ranging from 0.001” to 0.010” in both the machined and as-plated/coated condition.

3.3.2. Test Specimens

Low alloy steel test panels per Hamilton Sundstrand specimen drawing M-363-5 (see Figure 3-1) were coated with each of the candidate coatings. The test matrix indicated in Table 3-1 and Table 3-2 details the type and quantity of test panels for salt-spray testing per ASTM B-117.

3.3.2.1. Test Procedure

Table 3-1 . Summary of Samples As-Plated or HVOF-Coated

Plating/Coating	Thickness	No. of Samples
Nickel Plate per QQ-N-290, CL. 2, 500 Hv min, compressive stress 10,000 psi max	0.010"	3 each
	0.005"	
	0.001"	
WC/17Co	0.010"	3 each
	0.005"	
	0.001"	
WC/CoCr	0.010"	3 each
	0.005"	
	0.001"	
Tribaloy T-800	0.010"	3 each
	0.005"	
	0.001"	

Table 3-2 . Summary of Samples Following Surface Grinding (0.002" Type Stock Removal)

Plating/Coating	Thickness	No. of Samples
Nickel Plate per QQ-N-290, CL. 2, 500 Hv min, compressive stress 10,000 psi max	0.010"	3 each
	0.005"	
	0.001"	
WC/17Co	0.010"	3 each
	0.005"	
	0.001"	
WC/CoCr	0.010"	3 each
	0.005"	
	0.001"	
Tribaloy T-800	0.010"	3 each
	0.005"	
	0.001"	

Once the panels were coated and machined, the specimens were serialized. The back of the panel was masked with one piece of 4"-wide red plastic tape and the edges of the panels were dipped in red plating lacquer. This protected the edges from attack at the interface. The serial numbers were transferred to the front of each panel, on the lacquer edge, at the top and bottom. The panels were then placed in an ASTM B-117 salt spray cabinet. The panels were inspected daily and test logs were kept. The test logs noted the date when the specimens were placed in the cabinet, the date when red rust was first noted on the specimen, and the date the panels were pulled from the cabinet. The panels remained in the cabinet until three or more corrosion spots were noted or when any one spot was larger than 0.3" in diameter. Once the panels were removed, they were cleaned and photographed.

3.3.3. Test Results

Figure 3-2 through Figure 3-5 give photographs of the first, 0.001"-thick specimens from each coating group. Figure 3-6 and Figure 3-7 show photographs of the panels both before and after glass bead peening was used to flatten panels warped from the coating process.

3.3.4. Discussion

The high compressive stresses in the HVOF coatings caused the panels to warp substantially, as shown in Figure 3-6. To overcome this effect and restore flatness for grinding, the reverse sides of the panels were glass-bead-peened. The as-coated (not machined) panels were not peened. Even after peening, some panels still bowed slightly in the opposite direction, see Figure 3-7. To prevent uneven grinding, which would result in a non-uniform coating thickness, the edges of the panels were clamped to the table of the surface grinder to allow the middle of the panel to be machined. This setup was also required for the nickel-plated panels, which had bowed in tension creating a slightly concave surface.

The final coating thickness of the machined panels was determined by measuring the difference between the un-coated edge and the coated middle of the panel. This was done using deep throat micrometers with an accuracy of 0.0001".

3.3.5. Conclusions

The nickel plate provided the greatest level of protection to the substrate. With respect to the HVOF coatings, the WC/CoCr provided the best protection followed by the Tribaloy T-800 and the WC/Co, both of which performed poorly.

After 552 hours in the salt fog chamber, the panels were counted to determine how many had been pulled for corrosion that exceeded the maximum limit. The test results were as follows:

- 66% of the as-coated WC/Co panels and 100% of the machined WC/Co panels had been pulled from the chamber
- 55% of the Tribaloy as coated panels and 100% of the Tribaloy machined panels had been pulled from the chamber

- 55% of the WC/CoCr as-coated panels and 55% of the WC/CoCr machined panels had been pulled from the chamber
- 22% of the Nickel Plate as-coated panels and 25% of the Nickel plate machined panels had been pulled from the chamber.

The nickel plate applied to the panel was soft nickel with a resulting tensile residual stress rather than a hard nickel with a compressive residual stress. This was due to miscommunications within the plating facility. While this condition would be less than optimum for wear testing, we believe it had a negligible impact on the outcome of the corrosion tests. In our opinion, the state of coating residual stress had little effect on the barrier protection provided by the nickel.

The Tribaloy coating tended to “bleed” rust from many different areas dispersed over the coating surface. This is due to the higher porosity level in the Tribaloy allowing multiple paths for corrosives to reach the substrate.

The WC/Co and WC/CoCr corroded in one or two specific locations rather than many locations. Due to the very dense nature of the coatings, the coating must fail from a few random flaws in the coating rather than evenly dispersed porosity. The source of these flaws was therefore important. If they were generated due to the warping of the panel, it is possible that better corrosion resistance could be expected on actual components that can resist warping.

The machined specimens exhibited poorer corrosion resistance when compared with the as-coated panels, especially with the Tribaloy and WC/Co coatings. This was exacerbated by the grinding process, which was made difficult due to warping of the panels during coating.

Thicker coatings, generally, provided a higher level of corrosion protection.

3.3.6. Recommendations

Although the WC/CoCr did not perform as well as the nickel plate, it is still recommended as an alternate to the hard nickel plate specified in the rocker land repair. The nickel plate is applied at the repair depot to restore size of the hub arm bore. The production hub is made from low-alloy steel and is unprotected in this area. Corrosion of low-alloy steel will occur within a day in a salt fog cabinet, so any level of protection is beneficial. Additionally, the HVOF coating offers the added benefit of improved wear resistance, which will be discussed later in this report.

Based on discussions with corrosion and coating experts in the aerospace industry, warping of HVOF coated panels can result in cracking of the coating leading to poor test results. Though it could not be positively determined that any of the tested panels exhibited cracks due to panel warping, it was suspected as a possible contributor to the poor test results. On future corrosion tests, it is recommended that thicker test panels be utilized to minimize panel warping.

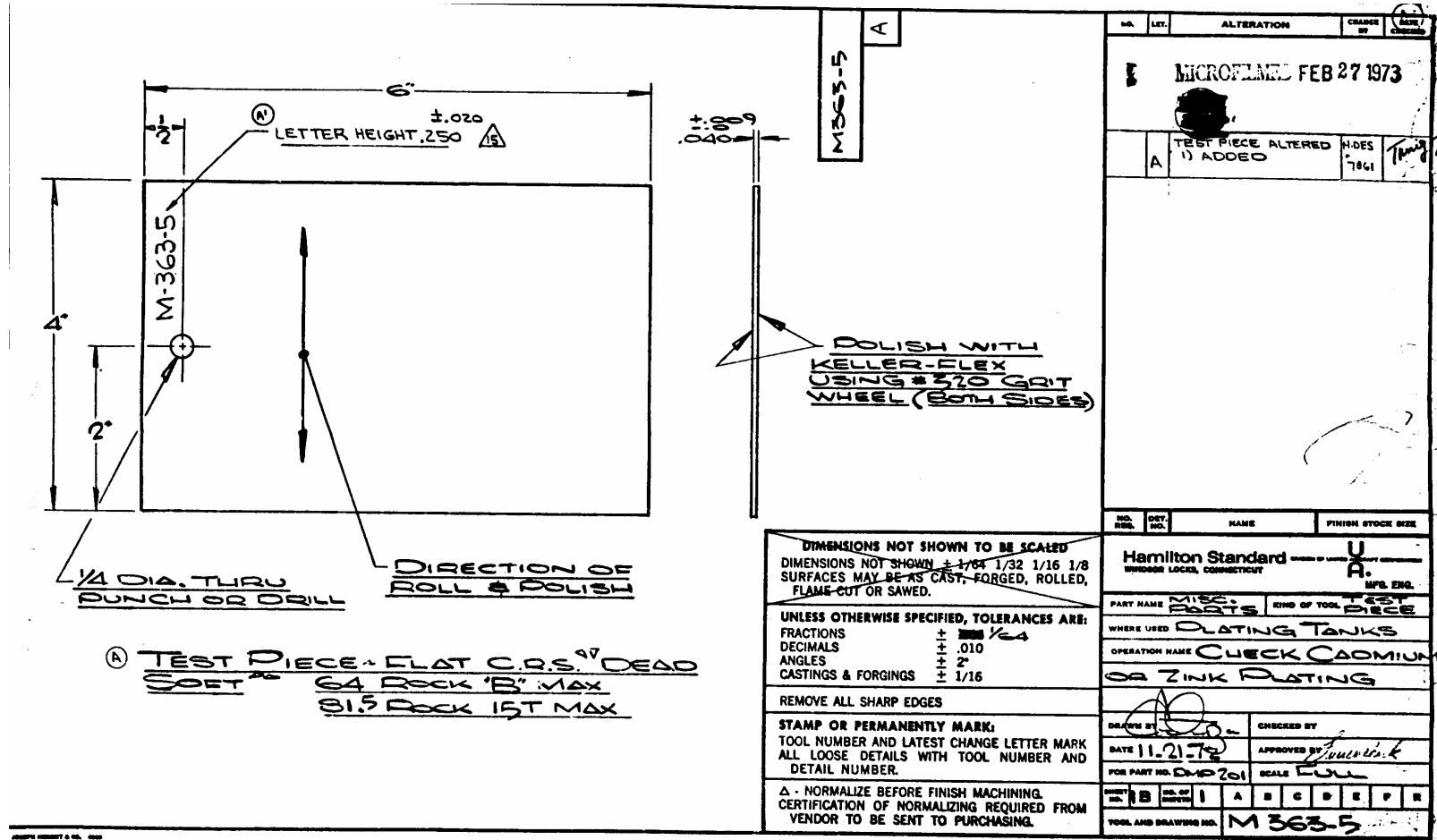

Figure 3-1. Flat Panel Corrosion Specimen



Figure 3-2. 0.001"-Thick WC/Co HVOF



Figure 3-3. 0.001"-Thick Nickel Plate



Figure 3-5. 0.001"-Thick WC/CoCr HVOF



Figure 3-4. 0.001"-Thick Tribaloy T-800 HVOF



Figure 3-6. WC/Co Coated Panel, Top Surface Coated

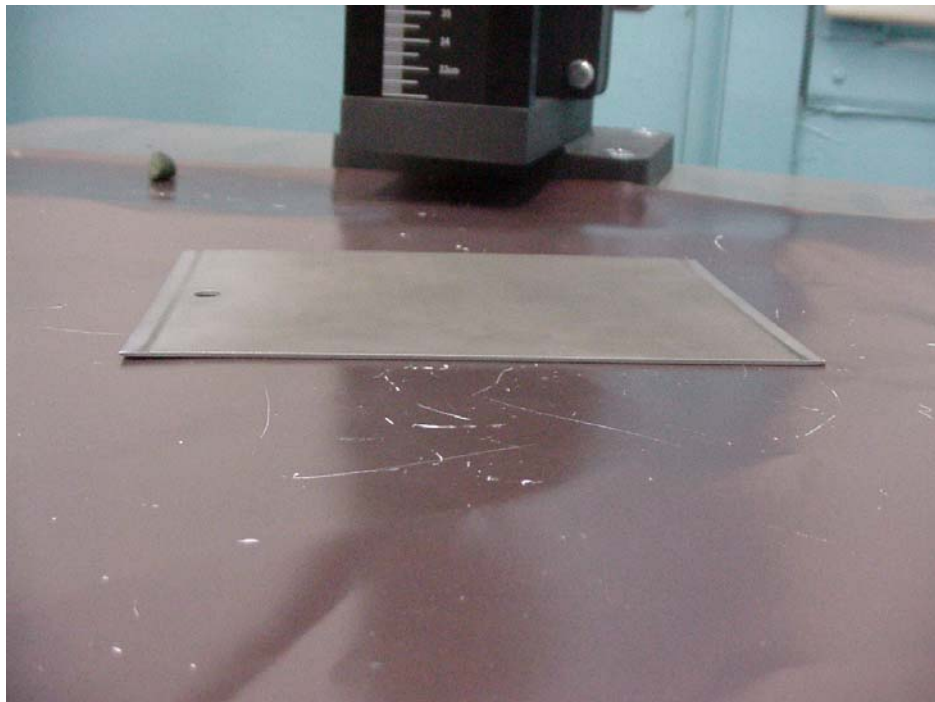

Figure 3-7. WC/Co Coated Panel, Top Surface Coated, Bottom Surface Glass Bead Peened

3.4. Fatigue

3.4.1. Introduction

The purpose of this fatigue test program was to evaluate the effects of HVOF coatings on the fatigue strength of high strength steel. Other characteristics to be evaluated were coating thickness, coating surface finish, effect of cold working the substrate, and the fatigue strength reduction of coated notched specimens.

This test program was set up with specific acceptance criteria as stated in the JTP issued by the HCAT Team. In brief, if the fatigue life curves of the HVOF coatings showed equivalent or superior fatigue properties to the EHC plating, then the HVOF coatings would be considered to have met the acceptance criteria.

3.4.2. Specimens

Test specimens were machined at Metcut Research Associates from AISI 4340 steel that had been heat treated to a hardness of Rockwell C 40-44 per the Hamilton Sundstrand heat treating specification HS 43. All smooth specimens were machined to drawing number 12X-1790 shown in Figure 3-8; the coatings were applied on top of the existing 0.200" minimum test section diameter so that the overall finished specimen diameters were to be 0.206", 0.220", and 0.230". The final coating thickness was created by plunge-grinding of the curved section of the specimen with contoured grinding wheels.

The WC/17Co and T-800 coated specimens had their coatings applied by Engelhard Surface Technologies of East Windsor, CT. The WC/17Co was applied per AMS 2447-7 but with additional controls on the spraying. The spraying parameters can be varied to provide different levels of residual stress, both compressive and tensile. The residual stress was controlled by the use of Almen strips used for shot-peening. The Almen "intensity" was specified to be within 0.008" - 0.012" of curvature on an Almen N strip. After all the specimens had been sprayed the process was reviewed and the actual Almen intensity was found to be more on the order of .020" of curvature.

The T-800 coating was applied using AMS 2447 as a guideline since this particular coating is not included in the specification; the similar T-400 coating is covered by this specification so it was felt to be an appropriate controlling document. The chrome plate was applied at Hamilton Sundstrand at the Special Processes Facility in Windsor Locks.

The notched specimens were constructed so the actual outside surface of the coating followed the $K_t = 2.7$ notch contour. The notch in the base material was machined oversize, the coating was applied, and the final notch contour was then machined into the coating itself. The configuration of this specimen is shown in drawing 12X-1791 included as Figure 3-9.

3.4.3. Test Procedure

Axial fatigue tests were conducted at a stress ratio (S_{min}/S_{max}) of $R = 0.1$ resulting in a positive mean stress being applied. Specimens expected to fracture at a low number of cycles were cycled at 5 Hz. Expected high cycle fractures were cycled at 59 Hz, with expected low cycle specimens being switched over to this higher speed as they reached lives beyond 400,000 cycles.

The “staircase method” of testing was utilized for the high-cycle-range specimens i.e., if no fracture of a specimen occurred by 10 million cycles, the stress level was increased and the specimen was cycled until fracture occurred.

Stress levels were set based on the base material minimum diameter that was specified to be 0.199” - 0.202”. The actual measured diameter of each specimen before the application of the coating was used in all cases.

See Table 3-3 for the fatigue test matrix.

Table 3-3 . Fatigue Test Matrix**HCAAT Specimen Fatigue Test Matrix**

# of Specimens	Cycle Count	Coating	Thickness	Specimen Geometry	Residual Stress	Surface Finish (min R _a)
15	LCF	none	N/A	Smooth	none	Polished
6	HCF	none	N/A	Smooth	none	Polished
6	HCF	WC-Co	0.003	Smooth	none	4
6	HCF	WC-Co	0.01	Smooth	none	4
6	HCF	WC-Co	0.015	Smooth	none	4
6	HCF	Tribaloy	0.003	Smooth	none	8
6	HCF	Tribaloy	0.01	Smooth	none	8
6	HCF	Tribaloy	0.015	Smooth	none	8
6	HCF	Cr Plate	0.003	Smooth	none	16
6	HCF	Cr Plate	0.01	Smooth	none	16
6	HCF	Cr Plate	0.015	Smooth	none	16
6	HCF	WC-Co	0.003	Smooth	peened*	4
6	HCF	WC-Co	0.01	Smooth	peened*	4
6	HCF	WC-Co	0.015	Smooth	peened*	4
6	HCF	Tribaloy	0.003	Smooth	peened*	8
6	HCF	Tribaloy	0.01	Smooth	peened*	8
6	HCF	Tribaloy	0.015	Smooth	peened*	8
6	HCF	Cr Plate	0.003	Smooth	peened*	16
6	HCF	Cr Plate	0.01	Smooth	peened*	16
6	HCF	Cr Plate	0.015	Smooth	peened*	16
15	HCF	WC-Co	0.003	Smooth	peened*	4
15	HCF	WC-Co	0.01	Smooth	peened*	4
15	HCF	WC-Co	0.015	Smooth	peened*	4
15	HCF	Tribaloy	0.003	Smooth	peened*	8
15	HCF	Tribaloy	0.01	Smooth	peened*	8
15	HCF	Tribaloy	0.015	Smooth	peened*	8
15	HCF	Cr Plate	0.003	Smooth	peened*	16
15	HCF	Cr Plate	0.01	Smooth	peened*	16
15	HCF	Cr Plate	0.015	Smooth	peened*	16
6	HCF	WC-Co	0.01	Notched	none	4
6	HCF	Tribaloy	0.01	Notched	none	8
15	LCF	WC-Co	0.01	Notched	none	4
15	LCF	Tribaloy	0.01	Notched	none	8
6	HCF	WC-Co	0.01	Smooth	peened*	16
6	HCF	Tribaloy	0.01	Smooth	peened*	16
15	LCF	WC-Co	0.01	Smooth	peened*	16
15	LCF	Tribaloy	0.01	Smooth	peened*	16
348	Total					

3.4.4. Testing Conditions

Type: Axial Fatigue per 12X-1790, 12X-1791

Material: AISI 4340 steel, HRC 40-44

Condition: See Table 3-3

Number Tested: See Table 3-3

Mean Stress: $R (S_{min}/S_{max}) = 0.1$

Machines: 20,000 lb hydraulic load frames at Metcut Research Associates

Test Speed: 5 or 59 Hz

3.4.5. Results

The results are shown in Figure 3-10 to Figure 3-14. Details of all the data are tabulated in the Joint Test Report. Table 3-4 summarizes the fatigue data obtained and locations of the data curves.

Table 3-4 . Summary of Fatigue Data Figures

Coating	Thickness (mil)	Peened	Notched	Figure
Bare		✓		Figure 3-10
				Figure 3-11
EHC	3	✓		Figure 3-10
	10	✓		Figure 3-10
	15	✓		Figure 3-10
	3			Figure 3-11
	10			Figure 3-11
	15			Figure 3-11
WC/17Co	3	✓		Figure 3-10
	10	✓		Figure 3-10
	15	✓		Figure 3-10
	3			Figure 3-11
	10			Figure 3-11
	10		✓	Figure 3-11
T-800	3	✓		Figure 3-10, Figure 3-12
	10	✓		Figure 3-10, Figure 3-13
	15	✓		Figure 3-10, Figure 3-14
	3			Figure 3-11, Figure 3-12
	10			Figure 3-11, Figure 3-13
	10		✓	Figure 3-11
	15			Figure 3-11, Figure 3-14

3.4.6. Discussion

AISI 4340 baseline fatigue strength was determined using a Sikorsky Aircraft Excel program that fits the curve using the following equation: $\sigma = \sigma_{\text{end}} (1 + B/(N/10^6)^y)$. The initial Beta-Gamma fit was then modified through the use of another Excel program that allows the manipulation of those variables to create a more precise fit. The resulting fatigue life curve can be seen in Figure 3-10. The shot peened WC/17Co and EHC data were analyzed in the same fashion, see Figure 3-10. The Beta-Gamma regression could not properly converge for the T-800 coated specimen data as the fatigue life curves all exhibited sharp “knees” to the curve shape between ½ to 2 million cycles. The fatigue curves for the T-800 specimens were visually fit into the curve instead.

The fatigue life curves for all coatings applied to shot-peened specimens are shown together in Figure 3-10. It becomes readily apparent when viewing these curves that the WC/17Co fatigue strengths were greater than the bare 4340 while the T-800 and EHC strengths are both below the bare 4340. Compared to each other, the T800 strengths were on the order of 75% of the WC/17Co and the EHC coating strengths is roughly half of the WC/17Co.

The increased fatigue strength of the WC/17Co specimens was thought to be created by one of the following: a) the compressive residual stress imparted by the shot-peening prior to the coating being applied, b) the ability of the coating itself to carry some of the load, c) the compressive residual stress imparted by the coating application process or d) some combination thereof. The strength did appear to be directly related to coating thickness so the coating load carrying capability was thought to be the major contributor to this effect.

A 0.015” strain gage was placed at the center of the hourglass portion of one unpeened 0.010”-thick WC/17Co specimen to determine the load versus strain response of a coated specimen. Load versus strain and load versus stroke responses were both linear, suggesting the coating was behaving identically to the substrate. The strain response indicated an apparent modulus greater than the steel modulus of 29 million psi so the WC/17Co is evidently carrying some of the load.

All conditions of the T-800 coating created a decrease in the fatigue strength of the 4340 steel, ranging from 13 to 21%. The average T-800 strength of 133 ksi for all conditions was 26% below the average WC/17Co strength of 180 ksi.

The three thicknesses of chrome plate all showed fatigue strength decreases despite the fact that the steel substrate had been shot-peened prior to plating. The EHC-plated specimens exhibited 38 to 51% lower fatigue strengths. This effect is more in line with chrome plating over unpeened steel so selected specimens were returned to HS and were subjected to visual and fluorescent penetrant inspections. The report from the National Destructive Test lab reported grinding cracks were found away from the test sections of specimens representing all three plating thicknesses. Figure 3-15 shows these cracks under normal lighting conditions.

Except for the coating applications, Metcut handled all aspects of specimen manufacturing. The specimens were provided with 0.015”-thick coatings and Metcut preformed post-coating grind of the specimens down to the final thicknesses of 0.003” and 0.010”. No specific machining instructions were given to Metcut, so their normal machining procedures were used. These procedures resulted in the cracks present in the chrome plate, which resulted in a severe strength degradation of the material. The WC/17Co and T-800 coatings underwent the same machining processes. Therefore, an unforeseen benefit is the fact that the WC/17Co can withstand a level

of machining that would be detrimental to chrome plate, without the adverse effect on strength.

The effect of surface finish on the T-800 and WC/17Co was negligible. The full impact of changing surface finishes was not realized, however, since the final grinding was in the longitudinal direction. It had been planned to utilize circumferential grinding for the final finishing as it was thought that grinding marks normal to the applied stress would create a greater probability of fatigue initiation.

The presence of shot-peening was found to have negligible effect on fatigue strength for both the T-800 and WC/17Co coatings. The non-peened specimen groups consisted of six specimens for each coating condition. The specimens were all tested in the high cycle mode with the purpose of obtaining data points beyond 100,000 cycles. For the WC/17Co, the results were somewhat interspersed with the shot-peened results; curves were manually fit through the data points. When the non-peened curves are plotted, Figure 3-11 shows that the base 4340 fatigue strength was again exceeded.

It should be noted that high-cycle fractures were not obtained for the T-800 non-peened groups. The fatigue lives obtained, along with the large number of 10 million cycle runouts, showed that with this limited sample the peening did not greatly affect the fatigue strength level but that the inflection point may have been altered. Figure 3-12 to Figure 3-14 shows the non-peened data points overlaid with the shot-peened T-800 data.

The non-peened EHC data exhibited the classic effect of substantial fatigue strength degradation. With the aforementioned presence of grinding cracks, the fatigue strength degradation was much larger than expected - on the order of 75%.

The notched fatigue tests conducted on non-peened specimens with a K_t of 2.7 demonstrated equivalent fatigue strength for the WC/17Co and T-800 coatings. The WC/17Co exhibited a K_f of 2.3 for $10^6 - 10^8$ cycles when compared directly against the unpeened $K_t = 1.0$ data. Since S/N curves were not generated for the T-800 unpeened tests, the notched data was compared against the peened T-800, $K_t = 1.0$ data since these two groups were not clearly showing significant differences. This resulted in a K_f of 1.95 for $10^7 - 10^8$ cycles. The S/N curves for these groups can be seen in Figure 3-11.

To summarize, the WC/17Co coating showed fatigue strength that was 35% higher than the T-800 fatigue strength and 95% higher than the EHC on 4340 steel. The 10^6 and 10^8 fatigue strengths were statistically analyzed for the four conditions of the peened WC/17Co that were tested. Each data point was projected out to 10^6 and 10^8 cycles by the Beta-Gamma equation and the projected points for each cycle level then had their mean, standard deviation, and coefficient of variation calculated. The results shown in Table 3-5 indicate excellent levels of scatter as the coefficients of variation were all fewer than 2%.

Since the fatigue scatter for the WC/17Co was so small, the superiority of this coating to the T-800 coating and EHC was clearly evident without the need for statistical breakdowns of the data. From a fatigue strength standpoint, the WC/17Co, when applied with the proper controls to create the desired state of coating residual stress, will outperform chrome plate. Testing showed that prior shot-peening of the base metal was not required to achieve this level of strength.

Table 3-5 . Statistical Analysis of Fatigue Strengths

Statistical Analysis of WC Fatigue Strengths

<u>.003" WC 4Ra</u>				<u>.010" WC 4Ra</u>				
Stress (Ksi)	# of Cycles	Stress When Projected To		Stress (Ksi)	# of Cycles	Stress When Projected To		
		10 ⁷ Cycles	10 ⁸ Cycles			10 ⁷ Cycles	10 ⁸ Cycles	
200	2,073	169.9	167.7	220	883	181.2	173.6	
200	2,045	169.8	167.6	220	1,266	182.7	175.0	
200	2,140	170.1	167.9	220	2,355	185.2	177.5	
200	2,820	171.9	169.7	220	3,197	186.5	178.7	
200	2,598	171.4	169.2	220	279	176.5	169.1	
190	15,087	172.3	170.0	210	26,270	186.3	178.6	
190	9,958	170.3	168.1	210	4,145	179.0	171.6	
190	22,372	174.0	171.8	210	15,216	184.2	176.5	
190	12,282	171.3	169.1	210	19,412	185.1	177.4	
190	9,643	170.1	167.9	210	3,735	178.6	171.2	
185	51,452	172.7	170.5	200	77,460	181.6	174.0	
185	53,903	172.9	170.7	200	39,013	179.0	171.5	
185	89,900	174.7	172.4	200	64,800	180.9	173.3	
182.5	126,632	173.4	171.2	200	101,651	182.6	175.0	
182.5	56,756	170.8	168.6	200	31,213	178.1	170.7	
180	1,168,157	176.5	174.3	195	228,678	181.0	173.5	
180	1,636,972	177.2	174.9	195	504,059	183.9	176.3	
175	4,819,162	174.0	171.8	190	3,538,435	186.3	178.5	
210	1,912	177.8	175.6	190	3,399,265	186.1	178.4	
170	6,969,020	169.5	167.4	180	5,595,018	178.0	170.6	
170	9,185,178	169.9	167.7	216	1,988	181.2	173.6	
175	10,244,832	175.0	172.8	180	10,000,600	180.0	172.5	
175	10,246,744	175.0	172.8					
	Xbar	172.5	170.3	ksi	Xbar	182.0	174.4	ksi
	Standard Deviation	2.54	2.51	ksi	Standard Deviation	3.10	2.97	ksi
	Coefficient of Variation	1.5%	1.5%		Coefficient of Variation	1.7%	1.7%	

<u>.010" WC 16Ra</u>				<u>.015" WC 4Ra</u>				
Stress (Ksi)	# of Cycles	Stress When Projected To		Stress (Ksi)	# of Cycles	Stress When Projected To		
		10 ⁷ Cycles	10 ⁸ Cycles			10 ⁷ Cycles	10 ⁸ Cycles	
225	162	178.1	175.1	230	7,516	193.8	188.4	
220	504	181.7	178.7	230	11,963	197.0	191.5	
215	4,630	190.0	186.8	230	5,363	191.5	186.1	
215	6,380	191.6	188.4	230	11,232	196.6	191.0	
215	3,739	188.9	185.8	230	8,391	194.6	189.1	
215	5,889	191.2	188.0	220	32,324	194.5	189.0	
210	8,797	188.6	185.5	220	40,189	195.8	190.3	
210	13,119	190.4	187.2	220	47,021	196.7	191.1	
210	8,896	188.7	185.5	220	21,450	192.1	186.7	
210	11,191	189.7	186.5	220	51,837	197.2	191.7	
200	197,599	190.9	187.7	210	152,886	193.8	188.3	
200	104,612	189.0	185.8	210	191,669	194.8	189.4	
200	52,800	186.7	183.5	210	665,073	200.3	194.7	
200	221,007	191.3	188.0	210	407,411	198.3	192.7	
200	40,164	185.7	182.6	210	1,725,969	204.1	198.4	
190	5,461,416	189.0	185.8	200	2,979,859	196.2	190.7	
190	1,512,155	186.4	183.3	200	2,297,768	195.4	189.9	
195	717,513	189.6	186.4	195	7,232,408	194.1	188.6	
195	1,892,904	191.8	188.6	195	8,082,790	194.4	188.9	
204	72,455	191.5	188.3	216	38,223	191.9	186.5	
204	58,041	190.7	187.5	216	187,555	200.3	194.7	
	Xbar	188.6	185.5	ksi	Xbar	195.9	190.4	ksi

3.4.7. Conclusions

The HVOF applied WC/17Co exhibited no direct fatigue strength degradation to the AISI 4340 steel. It showed superior fatigue strength to both the Tribaloy T-800 coating and EHC when applied to the 4340 steel. The WC/17Co showed a clear superiority to EHC, partly because the chrome-plated specimens showed evidence of grinding cracks from abusive grinding that created significant fatigue strength degradation. However, even using the industry accepted strength knockdown for chrome, the WC/17Co still had higher fatigue strength. The WC/17Co, which underwent the same machining treatment without any adverse effects, appears to be more process tolerant than the EHC plating.

The presence of shot-peening prior to coating application showed minimal effects on both the WC/17Co and the T-800. The final surface finish of these coatings did not create any strength differences; it should be noted, however, that the nature of the final grinding orientation was not optimal for evaluation of this characteristic.

The WC/17Co was found to have higher fatigue notch sensitivity than the T-800. However the actual strength levels in the presence of a notch were equivalent.

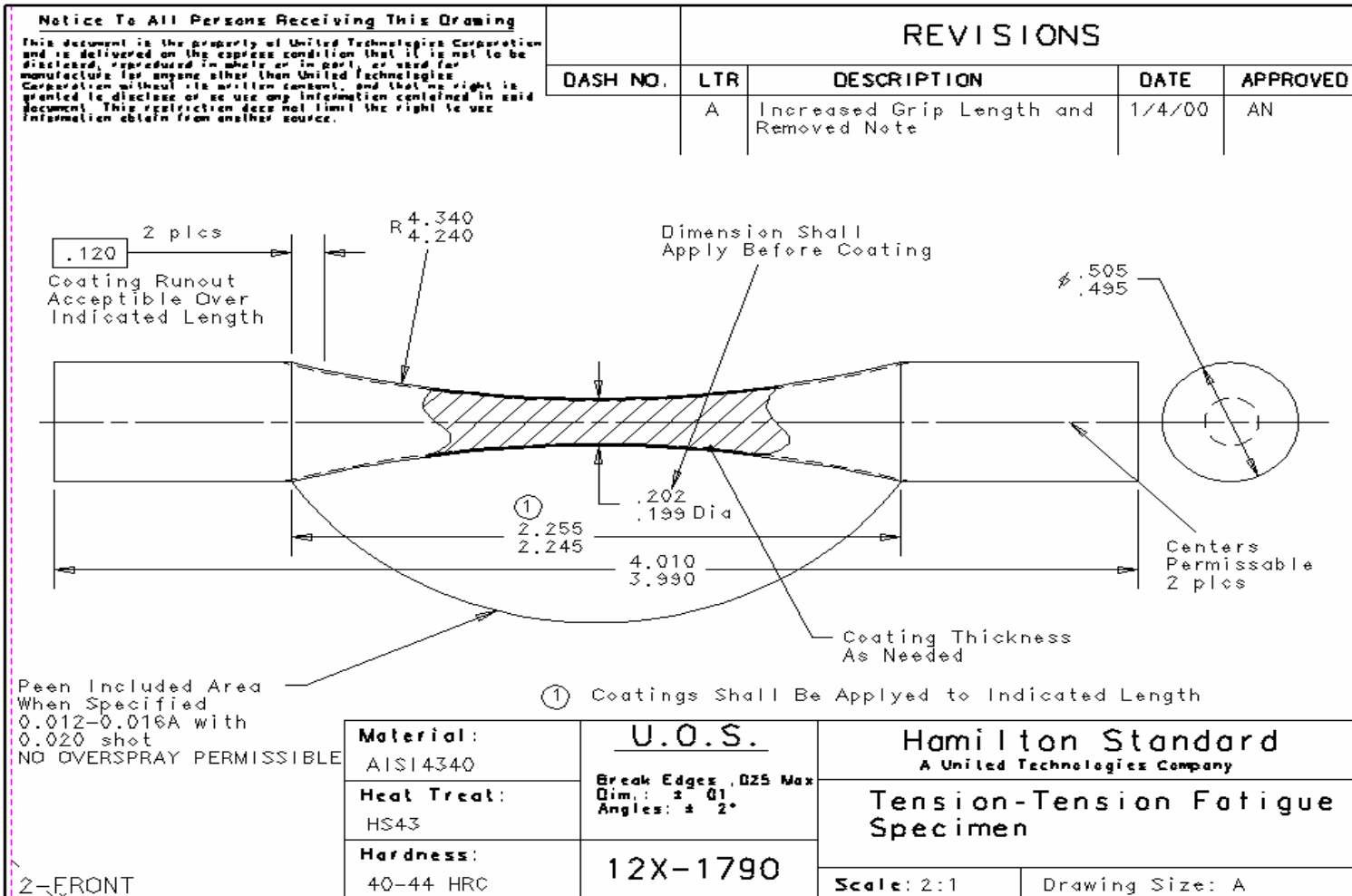

Figure 3-8. Tension/Tension Fatigue Specimen - Smooth

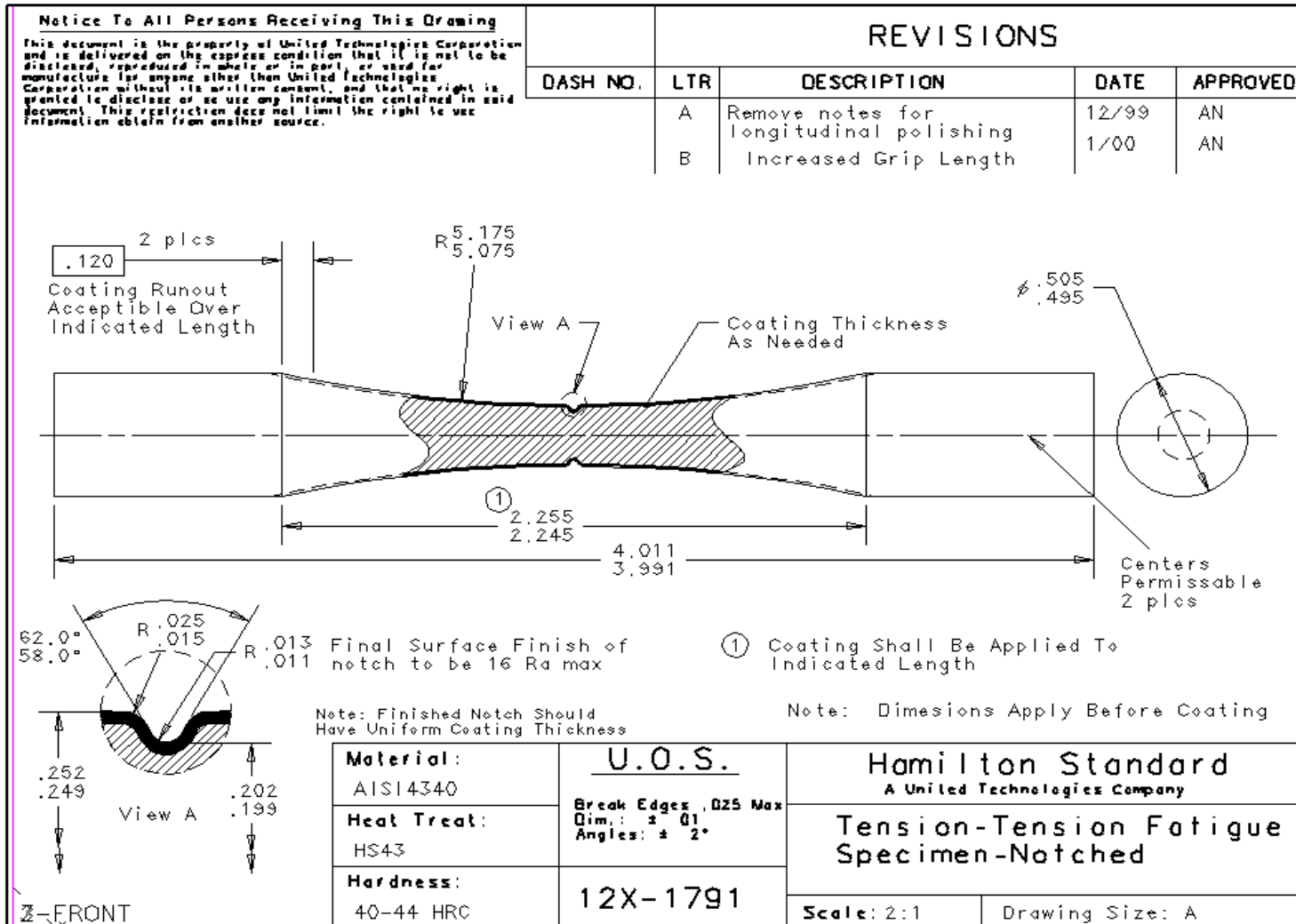

Figure 3-9. Tension/Tension Fatigue Specimen – Notched

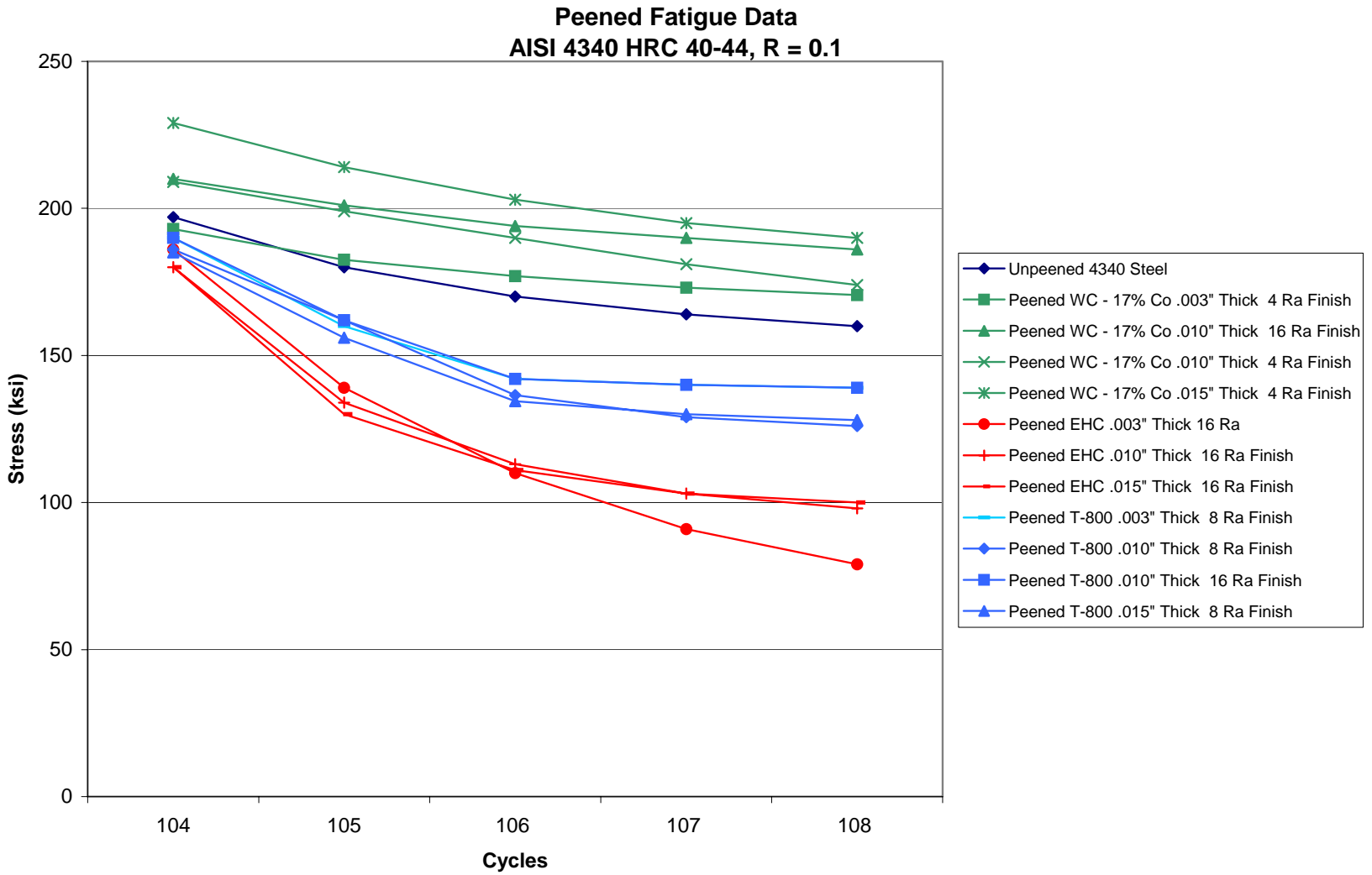

Figure 3-10. Peened Fatigue Data, R = 0.1

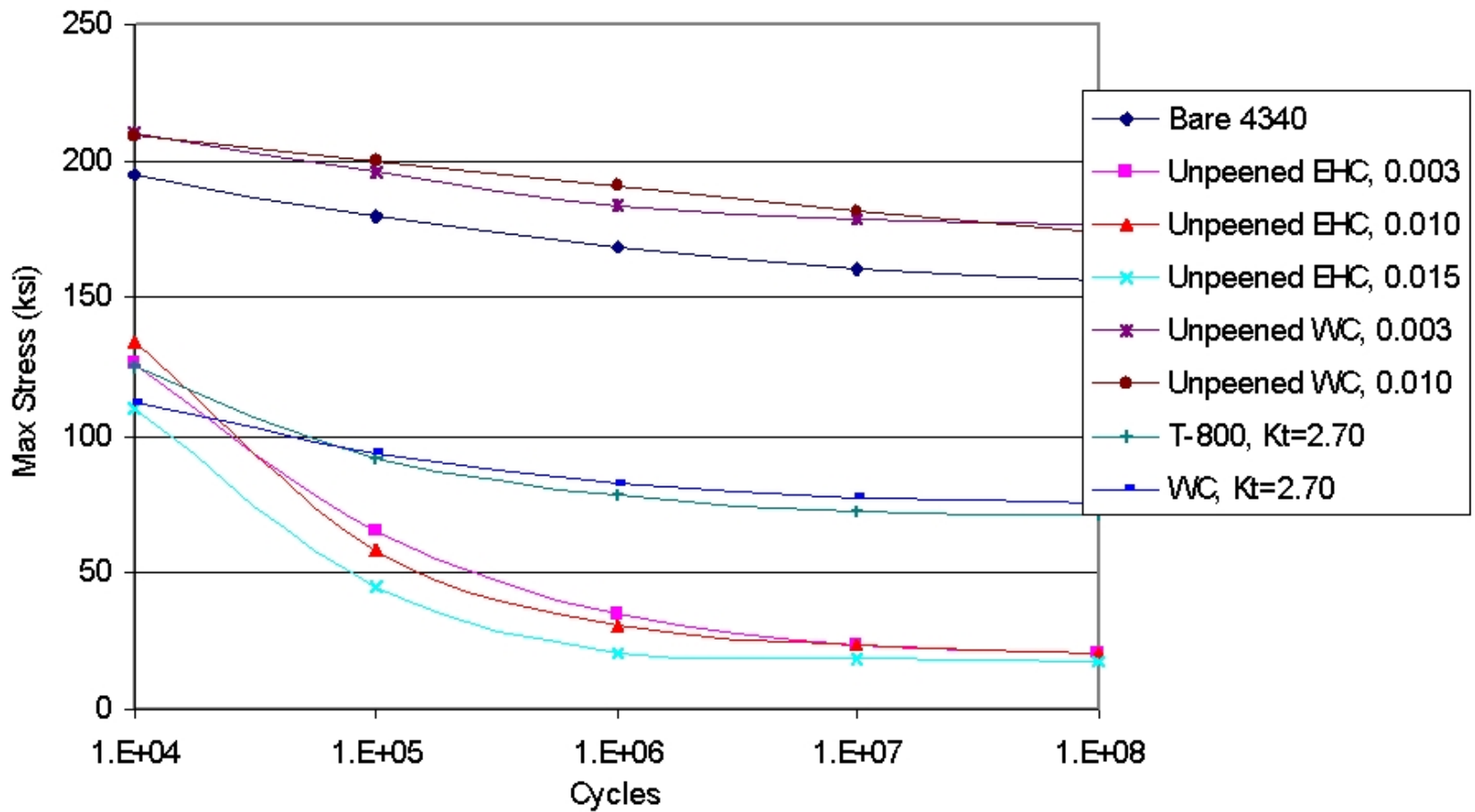

Figure 3-11. S/N Curves for Non-Peened Coatings and Notched Specimens

AISI 4340, HRC 40-44, R=0.1, .003" T-800

Green Points - Not Peened

Red Points - Peened

Open Circles Denoting Runouts

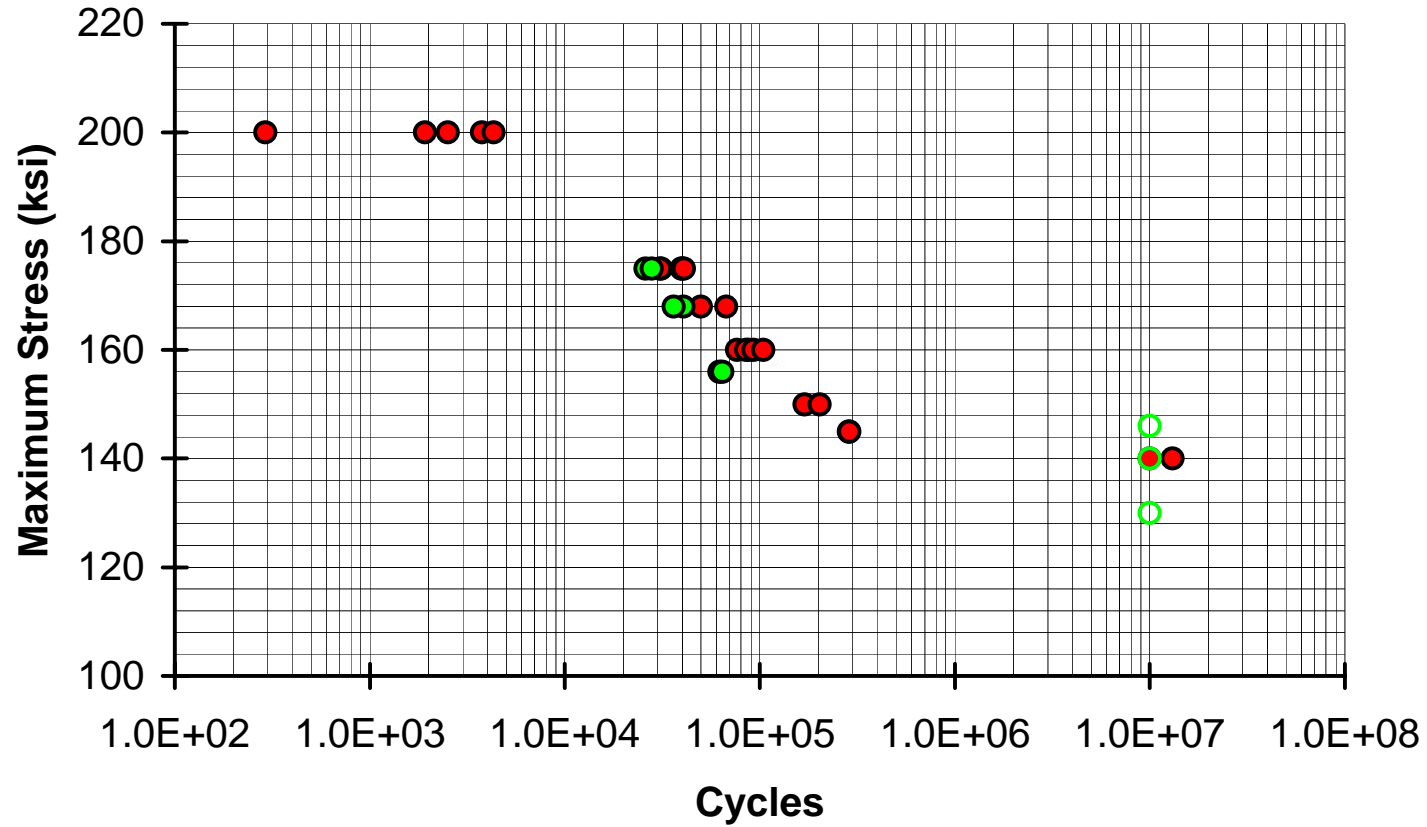

Figure 3-12. S/N Curves for 0.003" T-800 on 4340 Steel, R = 0.1

AISI 4340, HRC 40-44, R=0.1, T-800 .010

Green Points - Not Peened

Red Points - Peened

Open Circles Denoting Runouts

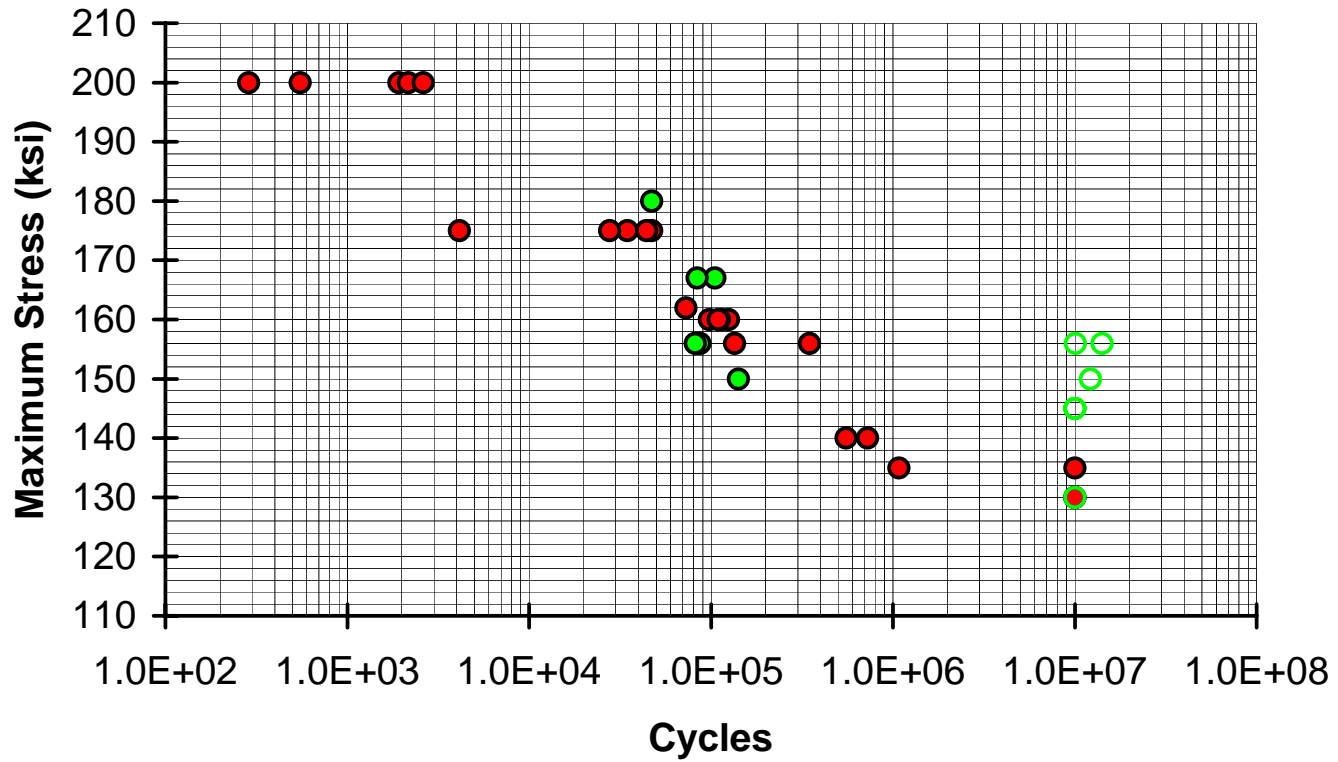

Figure 3-13. S/N Curves for 0.010"-thick T-800 on 4340 Steel, R = 0.1

AISI 4340, HRC 40-44, R=0.1, T-800 .015

Green Points - Not Peened

Red Points - Peened

Open Circles Denoting Runouts

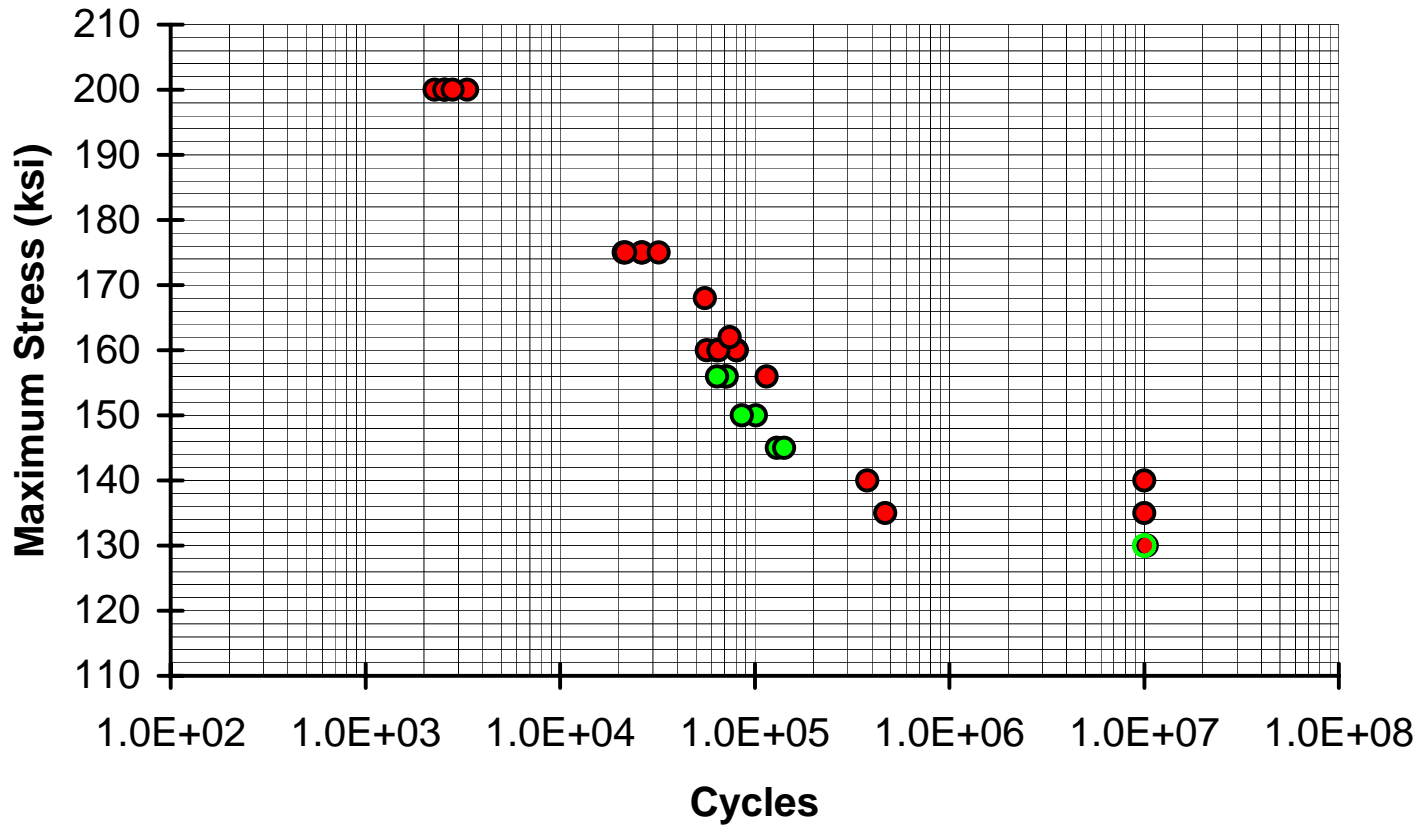

Figure 3-14. S/N Curves for 0.015"-thick T-800 on 4340 Steel, R = 0.1



Figure 3-15. White Light of EHC Coated Specimen Showing Cracks Created By Machining Process

3.5. Wear

3.5.1. Introduction

This test series was conducted to evaluate the wear properties of several HVOF coating candidates to replace chrome plating on the Propeller Hub and Low-Pitch-Stop Sleeve. All testing was performed on the Interlaken Servo-Hydraulic axial fatigue test frames in a specially designed specimen-holding fixture.

3.5.2. Specimens

The test selected to evaluate the wear characteristics of the baseline and candidate coatings was a flat-on-flat reciprocating test developed by Hamilton Sundstrand Materials Engineering. The counter-face material specimens were 2" x 0.25" x 0.125", see Figure 3-16. The coated specimens, shown in Figure 3-17, consisted of a 0.25"-thick panel, 1.50" wide by 8.00" long, coated on both sides with the test coating. The fixture design allows four specimens to be tested simultaneously with each coated panel using, see Figure 3-18.

A total of fifty-eight test runs were completed as detailed in the JTP. Table 3-6 is a matrix of the tests that were conducted. Each test run consisted of one panel and four counter-face specimens. Extra panel and counter-face specimens were made in the event that data verification was required.

The Hamilton Sundstrand Limited Production area manufactured all panel specimens. All hard-chrome-plated panels were prepared in the Hamilton Sundstrand Special Processes Plating Facility. All hard-nickel-plated panels were plated at Har-Conn Plating in West Hartford, CT. All HVOF-coated specimens were coated at Engelhard Surface Technologies in East Windsor, CT. The HVOF-coated samples were finish-ground by Engelhard using an outside machine house. The nickel- and chrome-plated samples were finish ground in the HS Limited Production area. All grinding was done across the 1.50" dimension of the panel leaving a perpendicular lay. The motion during the wear process is transverse to the lay of the grind just as it is with the actual parts.

Testing Specimens

Configuration:

- Coated Panel Specimens, per 12X-1768-S1
- Counter-face Material Specimen, per 12X-1768-S2

Panel Coatings:

- Chrome Plate per HS246
- WC/Co HVOF per AMS 2447-7
- Tribaloy T-800 per AMS 2447
- WC/Co Cr per AMS 2447-9
- Nickel Plate per QQ-N-290, Class 2, 500HV min, compressive stress 10,000 psi max

Counter-face Specimen Material:

- AISI4340 40-44HRC
- C17510 99HRB
- GLT Viton 90 Durometer
- 15% Glass Fiber Filled PTFE

End Item Hardware:

- 54H60 and 54460 Propeller Hub Tailshaft
- Low-Pitch-Stop Lever Sleeve
- 54460 Hub Rocker Land Seal Surface

Heat Treatment:

- HS43 for AISI4340

Surface Condition:

- 4 & 8 microinch Ra specified for Tungsten Carbide Coatings
- 8 and 16 microinch Ra for all other coatings
- Surface lay from grinding to be perpendicular to direction of motion

3.5.2.1. Test Procedure

Table 3-6 gives the test matrix for all of the wear tests performed. Testing was performed per the conditions established in the test matrix on the Interlaken Servo-Hydraulic axial fatigue test frames. Figure 3-19 and Figure 3-20 show fixture 12x-1768 held in the test frames with panel and specimens mounted. All tests were run in the presence of hydraulic oil per Mil-H-83282 and Mil-H-87257. Contamination consisting of iron oxide, silica sand, and Arizona Road Dust were added to Mil-H-83282 for the contaminated test runs. The oil delivery system consisted of a precision, fixed-flow peristaltic cassette pump capable of handling 10 separate pumping tubes. The tubes were 0.056”-ID Tygon LFL tubing. One tube was directed to each of the counter-face specimens. The flow rate was adjusted to approximately 0.5 ml/min, corresponding to approximately 22 drops per minute. After the oil was pumped to the specimens, it was collected in a drip pan and returned to the reservoir from which it was being pumped. The fluids from the non-contaminated test runs were filtered before returning the fluid to the reservoir.

All tests were performed at ambient temperature. Temperatures increased moderately due to frictional heating, but bulk specimen temperatures were maintained below 200°F. For the long-stroke tests, blowers were used to keep the samples cool. The stroke lengths were ± 0.010 ” for the dither tests and ± 0.250 ” for the long-stroke tests. The dither tests were run once for 1 million cycles and then the specimens were retired. The stroking tests were run three times for 100,000 cycles each run. Load levels were determined at the beginning of the test program to achieve a measurable amount of wear on the counter-face specimens. The levels selected for the steel and copper specimens were 500 and 1000 pounds. The glass-filled PTFE specimen dither tests were run at 1000 pounds. Due to the high initial wear rate of the Viton specimens, load levels of 100 and 200 pounds were used.

Table 3-6 . Wear Test Matrix

Wear Test Matrix For HCAT Chrome Replacement Project, On C-130, P-3, and E-2 Propeller Systems

Run #	Panel Specimen Coating	Small Flat Specimen	Lube Type	Contaminated Lube?	Stroke Length	Normal Load	Coating Surface Finish (µin, Ra)
1	Cr	AISI 4340	Mil-H-83282	No	Dither	Low	14-18
2	Cr	AISI 4340	Mil-H-83282	No	Large	High	14-18
3	Cr	AISI 4340	Mil-H-83282	No	Large	High	6-10
4	Cr	AISI 4340	Mil-H-83282	Yes	Dither	High	14-18
5	Cr	AISI 4340	Mil-H-83282	Yes	Large	Low	14-18
6	Cr	AISI 4340	Mil-H-87257	No	Large	High	14-18
7	Cr	Al Bronze	Mil-H-83282	No	Dither	High	14-18
8	Cr	Al Bronze	Mil-H-83282	No	Large	Low	14-18
9	Cr	Al Bronze	Mil-H-83282	No	Large	Low	6-10
10	Cr	Al Bronze	Mil-H-83282	Yes	Dither	Low	14-18
11	Cr	Al Bronze	Mil-H-83282	Yes	Large	High	14-18
12	Cr	Al Bronze	Mil-H-87257	No	Dither	High	14-18
13	Cr	Seal Material	Mil-H-83282	No	Dither	Low	14-18
14	Cr	Seal Material	Mil-H-83282	No	Large	High	14-18
15	Cr	Seal Material	Mil-H-83282	No	Large	High	6-10
16	Cr	Seal Material	Mil-H-83282	Yes	Dither	High	14-18
17	Cr	Seal Material	Mil-H-83282	Yes	Large	Low	14-18
18	Cr	Seal Material	Mil-H-87257	No	Large	High	14-18
19	WC-17Co	AISI 4340	Mil-H-83282	No	Dither	Low	6-10
20	WC-17Co	AISI 4340	Mil-H-83282	No	Large	High	6-10
21	WC-17Co	AISI 4340	Mil-H-83282	No	Large	High	3-5
22	WC-17Co	AISI 4340	Mil-H-83282	Yes	Dither	High	6-10
23	WC-17Co	AISI 4340	Mil-H-83282	Yes	Large	Low	6-10
24	WC-17Co	AISI 4340	Mil-H-87257	No	Large	High	6-10
25	WC-17Co	Al Bronze	Mil-H-83282	No	Dither	High	6-10
26	WC-17Co	Al Bronze	Mil-H-83282	No	Large	Low	6-10
27	WC-17Co	Al Bronze	Mil-H-83282	No	Large	Low	3-5
28	WC-17Co	Al Bronze	Mil-H-83282	Yes	Dither	Low	6-10
29	WC-17Co	Al Bronze	Mil-H-83282	Yes	Large	High	6-10
30	WC-17Co	Al Bronze	Mil-H-87257	No	Dither	High	6-10
31	WC-17Co	Seal Material	Mil-H-83282	No	Dither	Low	6-10
32	WC-17Co	Seal Material	Mil-H-83282	No	Large	High	6-10
33	WC-17Co	Seal Material	Mil-H-83282	No	Large	High	3-5
34	WC-17Co	Seal Material	Mil-H-83282	Yes	Dither	High	6-10
35	WC-17Co	Seal Material	Mil-H-83282	Yes	Large	Low	6-10
36	WC-17Co	Seal Material	Mil-H-87257	No	Large	High	6-10
37	Tribaloy T-800	AISI 4340	Mil-H-83282	No	Dither	Low	14-18
38	Tribaloy T-800	AISI 4340	Mil-H-83282	No	Large	High	14-18
39	Tribaloy T-800	AISI 4340	Mil-H-83282	No	Large	High	6-10
40	Tribaloy T-800	AISI 4340	Mil-H-83282	Yes	Dither	High	14-18
41	Tribaloy T-800	AISI 4340	Mil-H-83282	Yes	Large	Low	14-18
42	Tribaloy T-800	AISI 4340	Mil-H-87257	No	Large	High	14-18
43	Tribaloy T-800	Al Bronze	Mil-H-83282	No	Dither	High	14-18
44	Tribaloy T-800	Al Bronze	Mil-H-83282	No	Large	Low	14-18
45	Tribaloy T-800	Al Bronze	Mil-H-83282	No	Large	Low	6-10
46	Tribaloy T-800	Al Bronze	Mil-H-83282	Yes	Dither	Low	14-18
47	Tribaloy T-800	Al Bronze	Mil-H-83282	Yes	Large	High	14-18
48	Tribaloy T-800	Al Bronze	Mil-H-87257	No	Dither	High	14-18
49	Tribaloy T-800	Seal Material	Mil-H-83282	No	Dither	Low	14-18
50	Tribaloy T-800	Seal Material	Mil-H-83282	No	Large	High	14-18
51	Tribaloy T-800	Seal Material	Mil-H-83282	No	Large	High	6-10
52	Tribaloy T-800	Seal Material	Mil-H-83282	Yes	Dither	High	14-18
53	Tribaloy T-800	Seal Material	Mil-H-83282	Yes	Large	Low	14-18
54	Tribaloy T-800	Seal Material	Mil-H-87257	No	Large	High	14-18
55	Ni-Plate	Glass Filled PTFE	Mil-H-83282	No	Dither	High	6-10
56	Ni-Plate	Glass Filled PTFE	Mil-H-83282	Yes	Dither	High	6-10
57	WCCoCr	Glass Filled PTFE	Mil-H-83282	No	Dither	High	3-5
58	WCCoCr	Glass Filled PTFE	Mil-H-83282	Yes	Dither	High	3-5

Measurements of the panel surface finishes were made using a Tokyo Seimitsu Surfcom 570A surface texture machine. Average Roughness Ra and RMS roughness were recorded as well as skewness, kurtosis, mean-peak-height, and three Abbott Bearing-Area Curve Parameters, Rpk, Rvk and Rk. When required, wear scar measurements were made with the aforementioned surface texture machine. This stylus-type profilometer was used to generate a trace of the panel surface waviness in the lengthwise direction. The profilometer stylus traversed the entire length of the panels starting in the unworn area, continuing through the wear scar, and finishing at the unworn area on the opposite end. A minimum of two traces was made on each panel. – one along each edge – and the results were averaged. From these traces, wear volume was calculated.

The test variables are summarized below:

Test Variables

Testing Temperature:

- Room temperature plus moderate frictional heating

Test Conditions:

- Reciprocating Sliding (long-stroke) Test – 300,000 Total Cycles, ± 0.25 ” Triangle Wave at 2 hz
- Short-Stroke Dither Test – 1,000,000 Total Cycles, ± 0.010 ” Sine Wave at 15 hz
- Load Level – 500 and 1000 pound levels for Steel, Copper and 15% Glass Filled PTFE materials, 100 and 200 pounds for Viton

Contamination

- Contaminants per 1 gallon of hydraulic oil,
 - o 0-5 micron Iron Oxide – 28.5g
 - o 5-10 micron Iron Oxide – 1.5g
 - o 40-50 mesh Sharp Silica Sand – 1g
 - o 50-100 mesh Sharp Silica Sand – 1g
 - o Course Arizona Road Dust (Conforming to A.C. Spark Plug Co. P/N 1543637) – 8g

Machines:

- Interlaken frame #4 clean Mil-H-83282 oil testing
- Interlaken frame #5 contaminated Mil-H-83282 and clean Mil-H-87257

Due to the difficulty in making wear scar measurements of some panels and because of the different types of wear noted on the panels, a visual rating method was developed. The scale had a range of one through five and was based on the severity of wear relative to how a seal would perform against that surface. A rating of one corresponded to no wear. A rating of two, three or four corresponded to mild, medium and severe adhesive or abrasive wear, respectively. A rating of five corresponded to pitting of the coating.

Counter-face specimens had to be bonded into aluminum or steel holders. The specimens were

weighed to the nearest 0.0001 gram before they were bonded. After bonding, the specimens were placed in oil at 200°F for 24 hours to allow the adhesive to soak up as much of the oil as it would during the test. The samples were removed from the oil, cleaned and weighed again prior to the test run. After each test run, the samples were cleaned and weighed. Once testing of the specimens was complete, the specimens were removed from the holder, cleaned and weighed again. With the exception of the Viton specimens, the counter-face specimens were cleaned in a beaker of acetone and a sonic cleaner for 5 minutes. The Viton specimens were cleaned similarly, but rather than acetone, hexane was used followed by an isopropyl alcohol rinse.

Due to the low weight loss observed in the low-density Viton material and because of its propensity to absorb small amounts of oil and solvents, micrometer measurements of the wear scars were made to help calculate volume loss. These measurements were made once the specimens were removed from the aluminum holders. The thickness of the rubber in an unworn area of the specimen was compared to the thickness of the rubber in the worn area. The difference in these reading times the width and length of the wear scar constituted the volume loss.

3.5.3. Results

Figure 3-21 compares the wear coefficients calculated for the steel counter-face specimens against each coating tested. Figure 3-22 is a graphical representation of the condition of the panels after testing with the steel counter-face specimens. Figure 3-23 through Figure 3-25 contain photographs of EHC, WC/Co, and T-800 specimens that were exposed to the short-stroke dither test in contaminated oil against steel counter-faces. Figure 3-26 compares wear coefficients for the copper counter-face specimens. Figure 3-27 is a graphical representation of the condition of the panels after testing against the copper counter-face specimens. Figure 3-28 compares the wear coefficients calculated from wear scar measurements of the panel specimens tested against the copper counter-face specimens. Figure 3-29 through Figure 3-31 contain photographs of EHC, WC/Co, and T-800 specimens tested under long-stroke conditions with copper counter-faces. Figure 3-32 compares the wear coefficient of the Viton counter-face specimens. Figure 3-33 is a graphical representation of the condition of the panels after testing against the Viton counter-face specimens. Figure 3-34 compares the wear coefficients of the glass-filled PTFE counter-face specimens. Figure 3-35 is a graphical representation of the condition of the panels after completion of testing with the PTFE counter-face specimens. Figure 3-36 and Figure 3-37 contain photographs of EHN and WC/CoCr specimens tested under short-stroke dither conditions against 15% glass-filled PTFE counter-faces. Figure 3-38 compares the friction coefficients of the tests with steel, copper or Viton counter-face specimens. Figure 3-39 compares the friction coefficients of the tests with glass filled PTFE counter-face specimens. Figure 3-40 through Figure 3-45 are photomicrographs of all the coatings tested.

3.5.3.1. Steel Counter-Face Testing

The wear coefficients of the steel counter-face specimens were comparable when mated against either EHC or WC/Co coated panels. The wear coefficient values of the steel specimens against T-800 coated panels were lower for all cases except under contaminated stroking conditions.

The coating wear of the panels was noted as either mild or no wear for all coatings in non-contaminated conditions. In the presence of contamination and with a short dithering stroke, the

EHC and T-800 coatings exhibited significant pitting. The coating did not separate in an adhesive mode but rather in a cohesive mode. All four specimens against the EHC-coated panel exhibited this type of failure, while only one specimen against the T-800 test panel exhibited this damage.

The alternate oil type, Mil-PRF-87257 had no significant effect on the wear performance of either the steel or coated specimens.

Reducing the coating surface roughness produced less wear on the steel specimens while having no significant effect on the performance of the coatings. The rougher WC/Co specimens were measured at 7 Ra average, while the finer specimen was 2 Ra. The rougher EHC specimens were measured at 11 Ra average, while the finer specimen was 3 Ra. The rougher T-800 specimens were measured at 12 Ra average, while the finer specimen was 5 Ra.

The friction coefficients generally ranged from 0.11 to 0.18 for all tests. Under contaminated conditions, the friction coefficients were higher.

3.5.3.2. Copper Counter-Face Specimens

The wear coefficients of the copper counter-face specimens were lower against the WC/Co panels, under all test conditions, than either the EHC or T-800 coatings. The wear coefficients of the copper counter-face specimens against the EHC-coated panels were in all cases greater than those against the T-800, except for the high load, large-stroke test case where the outcome was reversed.

The WC/Co coating exhibited a far lower wear coefficient than either the EHC or T-800 coatings. Under all test conditions with the Mil-PRF-83282 hydraulic oil, the coating exhibited no measurable wear. With the Mil-PRF-87257, only minimal wear was noted. This wear was 7.5 times less than EHC and 15.5 times less than T-800 under comparable test conditions. The T-800 outperformed the EHC under all reciprocating sliding conditions, and the EHC outperformed the T-800 under all dithering conditions.

The alternate oil type, Mil-PRF-87257, had no significant effect on the coating performance and only seemed to affect the copper specimens when mated with EHC. In that case, the wear was reduced by 8 times.

When the coating surface roughness was reduced, there was no significant effect on the wear coefficients. The only effect on the copper specimen wear coefficient was against the T-800 coating where the finer surface roughness produced 5 times more wear on the copper specimens. It should be noted that the surface roughness of the WC/Co panels was not effectively evaluated because all of the panels were finished to an average of 4 Ra rather than some at 4 and some at 8, as specified. The rougher T-800 specimens were measured at 10 Ra average, with the finer specimen at 6 Ra. The rougher EHC specimens were measured at 11 Ra, with the finer specimen at 2 Ra.

The friction coefficients ranged from 0.07 to 0.25. Generally, the friction coefficients of the EHC and T-800 were of similar magnitude and both were higher than the WC/Co. Under high load, large-stroke contaminated oil conditions, the WC/Co had a similar friction coefficient as the T-800 and EHC.

3.5.3.3. Viton Counter-Face Specimens

The Viton specimens tested against the WC/Co coated panels exhibited the lowest wear coefficient in all non-contaminated test runs. When contamination was added all of the wear coefficients were reduced. Under microscopic inspection, contaminants were observed imbedded in the elastomer surface. These contaminants could have provided increased abrasion resistance to the elastomers. Further contaminated testing and SEM inspection of the elastomers could provide more information about this phenomenon but was beyond the scope of this test series.

There was no visible wear on panels tested in uncontaminated oil. With contaminated oil, very light scratches were observed on the EHC and T-800. The WC/Co exhibited only light oil staining on the panel where the counter-face specimens made contact.

The alternate oil made a dramatic difference in the wear coefficient of the Viton specimens, especially against the T-800 coating. The increase in wear coefficient of the Viton against the T-800 specimen with Mil-PRF-87257 oil was more than eight times that of the same specimens in Mil-PRF-83282 oil. The Mil-PRF-87257 hydraulic oil only increased the wear coefficients on the WC/Co and EHC coatings by a factor of 2.

The T-800 panel surface roughness did not have a significant effect on the Viton wear coefficient within the range of roughness evaluated. Both EHC and WC/Co coatings exhibited no measured differences in the surface roughness from specimen to specimen, and therefore it could not be determined if surface roughness played a role. The average surface roughness of the EHC specimens was 9 Ra while the WC/Co specimens were 4 Ra. The rougher T-800 specimens were measured at an average of 9 Ra while the smoother specimen was 5.5 Ra.

The friction coefficients for all test runs ranged from 0.1 to 0.4. Generally, the short-stroke dither testing produced higher friction coefficients compared to the long stroke tests due primarily to a reduction in the oil film thickness from low-amplitude motion. The WC/Co was generally equivalent or lower in friction coefficient than either the EHC or T-800, with the exception of the high load, short-stroke dither testing with contaminated oil. The friction coefficient also increased for all coatings in the presence of the Mil-PRF-87257.

3.5.3.4. 15% Glass-Filled PTFE Counter-Faces

The wear coefficients of the PTFE specimens tested against the WC/CoCr coating were slightly lower than those tested against the EHN. This difference may be due to the lower surface roughness of the WC/CoCr coatings or due to the deterioration of the EHN surface due to abrasion by the glass-filled PTFE.

The EHN-coated panels exhibited early stages of abrasion at the outline of the PTFE specimens. The WC/CoCr specimens exhibited only oil staining at the contact point between the PTFE specimen and the panel.

In the case of both WC/CoCr and EHN, the friction coefficients increased from 0.04 at the beginning of each test run to 0.06 by the end.

Contaminated oil causes an increase in wear coefficient of the PTFE specimen with no significant change to the panel wear or friction coefficient.

3.5.4. Discussion

The steel specimens exhibited much less wear than the copper specimens at comparable load levels. This was because the base of both hydraulic oils contains some level of tri-phenol phosphate and can contain up to 3% tri-cresyl phosphate as needed to meet the lubricity requirements of the specification. These lubricants only provide significant benefit to ferrous alloys [3.2]. In the case of the other materials, only the viscosity of the oil helped to reduce wear.

Without contamination, the wear rates of all the steel specimens were relatively low, regardless of load or stroke length. With contamination, adhesion between the steel specimens and the panel coatings became more prominent. Under short-stroke dithering conditions, this adhesion translated to substantial pitting of the chrome and Tribaloy coatings due to pullout of the coating. Under long-stroke conditions, the chrome plate and Tribaloy exhibited increased scoring of the panel in the wear area. The WC/Co coating exhibited a small 0.1-inch diameter area where adhesion of one of the steel specimens to the panel took place. No coating pullout from this panel was found. The WC/Co contaminated test panel looked the same as the non-contaminated test panels under the long-stroke conditions. The friction coefficient increased for the chrome and Tribaloy coatings under contaminated conditions, whereas the tungsten carbide remained the same.

After testing, the first panel tested from each lot was sectioned so that a representative micro could be made of each coating. These micros were examined metallographically and micro-hardness measurements taken to determine coating quality. Microphotographs of the coating structure can be found in Figure 3-40 through Figure 3-44. The chrome and nickel plate layers were dense with no bond line separation. The hardness values met specification for both plating samples. The nickel plate exhibited good ductility (no cracking of the coating) under 300, 500, or 1000 gram loading. The nickel plate was also etched to show the grain structure, see Figure 3-45. The chrome plating exhibited cracks perpendicular to the coating and substrate surface under the 300-gram loading. Two cracks were formed outside the hardness impression just beyond the points of the diamond.

The WC/Co and WC/CoCr HVOF coatings both exhibited porosity in the range of 0.5 - 0.9% with less than 10% interface contamination. No interface separation or coating cracking was noted in any sprayed coatings. The Tribaloy exhibited 1.4 - 1.6% porosity, which is close to the specified 1% within a reasonable error in measurement. The bondline contamination, was 16% due to a couple of large pores in the field of view that was analyzed. This is above the 10% allowed by the specification. This was of minimal consequence relative to the data collected because the adhesion strength was adequate and the large pores did not show up in every field of view.

Neither the WC/Co nor the WC/CoCr HVOF coatings exhibited cracking when subjected to hardness impressions. The Tribaloy showed signs of cracking with a 300 grams hardness impression. The cracks were much more substantial than those found in the chrome plate, occurring through and around the impression and always parallel to the coating and substrate surfaces, see Figure 3-46. This could indicate poor inter-splat adhesion of the coating, and could result in higher wear rates under sliding wear conditions, see Figure 3-47.

3.5.5. General Conclusions

The WC/Co coating outperformed both EHC and Tribaloy T-800 coatings in both coating wear performance and counter-face wear performance under all test conditions. Both EHC and T-800 exhibited pitting from dither wear testing against steel counter-faces in contaminated oil. Both EHC and T-800 exhibited significant adhesive wear of the coatings and of the counter-face specimens when tested against copper alloy C17510. The Viton seal material exhibited a lower wear coefficient against the WC/Co than either the T-800 or EHC.

The WC/CoCr coating outperformed the EHN plating in coating wear performance both with and without contamination. Additionally, the 15% glass-filled PTFE counter-face specimens exhibited lower wear coefficients when tested against the WC/CoCr coating.

The coating hardness was evaluated on the first test panel of each coating group. All readings were taken at 300 grams on a Vickers micro-hardness machine, except for the hard nickel where some readings were taken at 100 grams. This lower load was used because the 300-gram diamond impression was too large for the thickness of the coating on one side of the panel. The average EHC hardness was 873. The average WC/Co hardness was 1220. The average T-800 hardness was 574. The average EHN hardness was 631. The average WC/CoCr hardness was 1287. All coatings met the requirements of their associated specifications. It should be noted however that the T-800 hardness impressions were extensively cracked, most likely due to poor coating ductility.

3.5.6. Recommendations

Based on the wear data collected, the WC/Co HVOF coating is a suitable replacement for the chrome plating used on the 54H60 and 54460 propeller-hub tail shafts and low-pitch-stop lever sleeves. The WC/CoCr HVOF coating is also considered an acceptable replacement for the hard nickel plate on the 54460 rocker land.

For future testing, it is recommended that the counter-face specimen bonding procedure be eliminated. This would eliminate a significant amount of time spent presoaking the specimens in oil to reach weight equilibrium. Also, depending on the holding device, the weight measurements taken between test runs would be much more accurate.

The Tribaloy T-800 coating did not perform as well as the other coatings and should not be used in these applications. Further development work is required to optimize the spray parameters to improve the coating properties. Specifically, ductility and cohesive properties of the coating should be investigated.

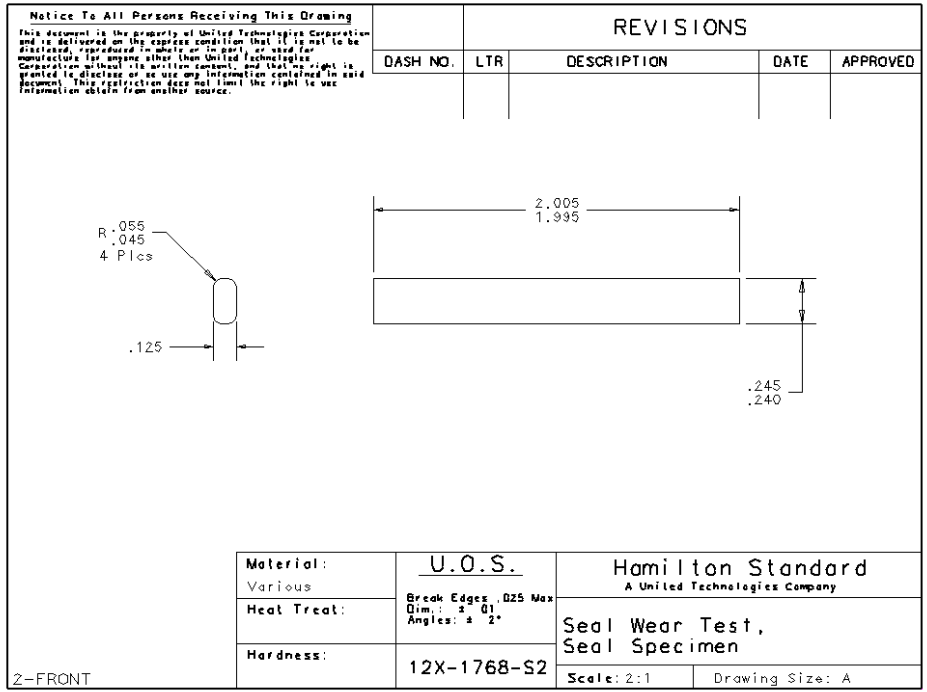

Figure 3-16. Counter-Face Wear Specimen

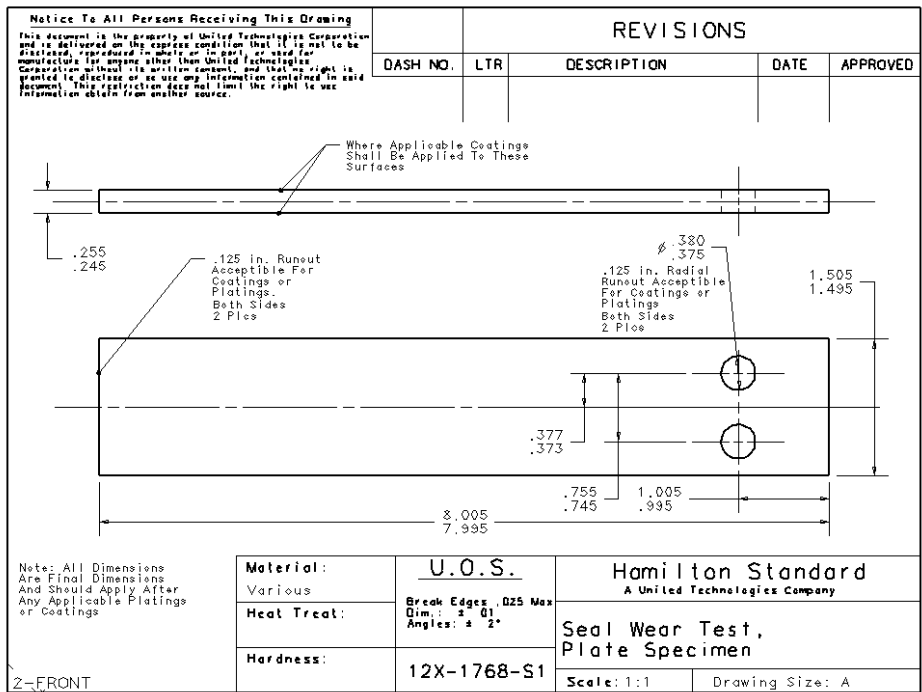

Figure 3-17. Coated Panel Wear Specimen

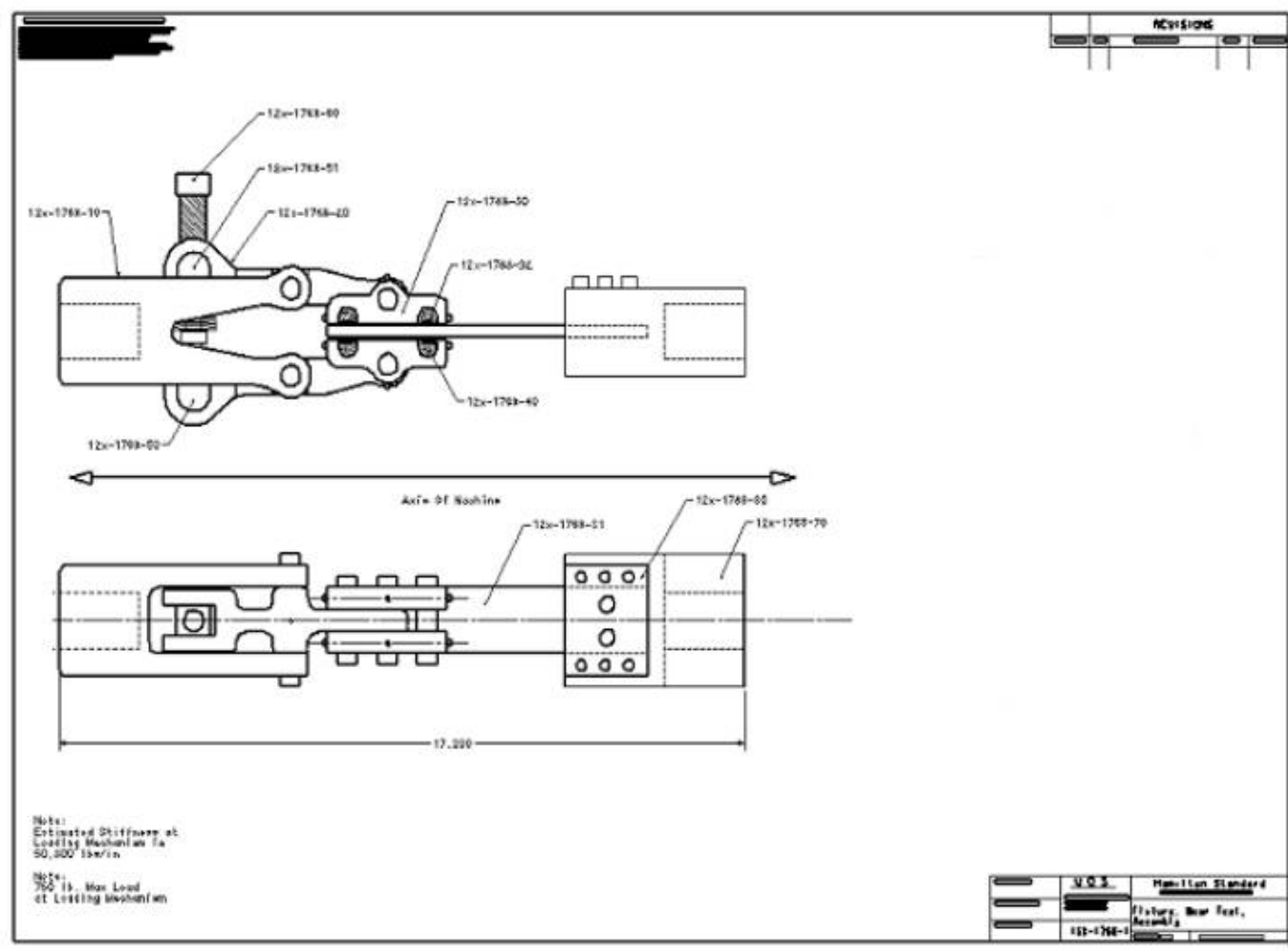

Figure 3-18. Wear Test Specimen Assembly



22,000 pound servo-hydraulic fatigue test frame



Test fixture including oil drip pan

Figure 3-19. Wear Test Fixture in Test Frame

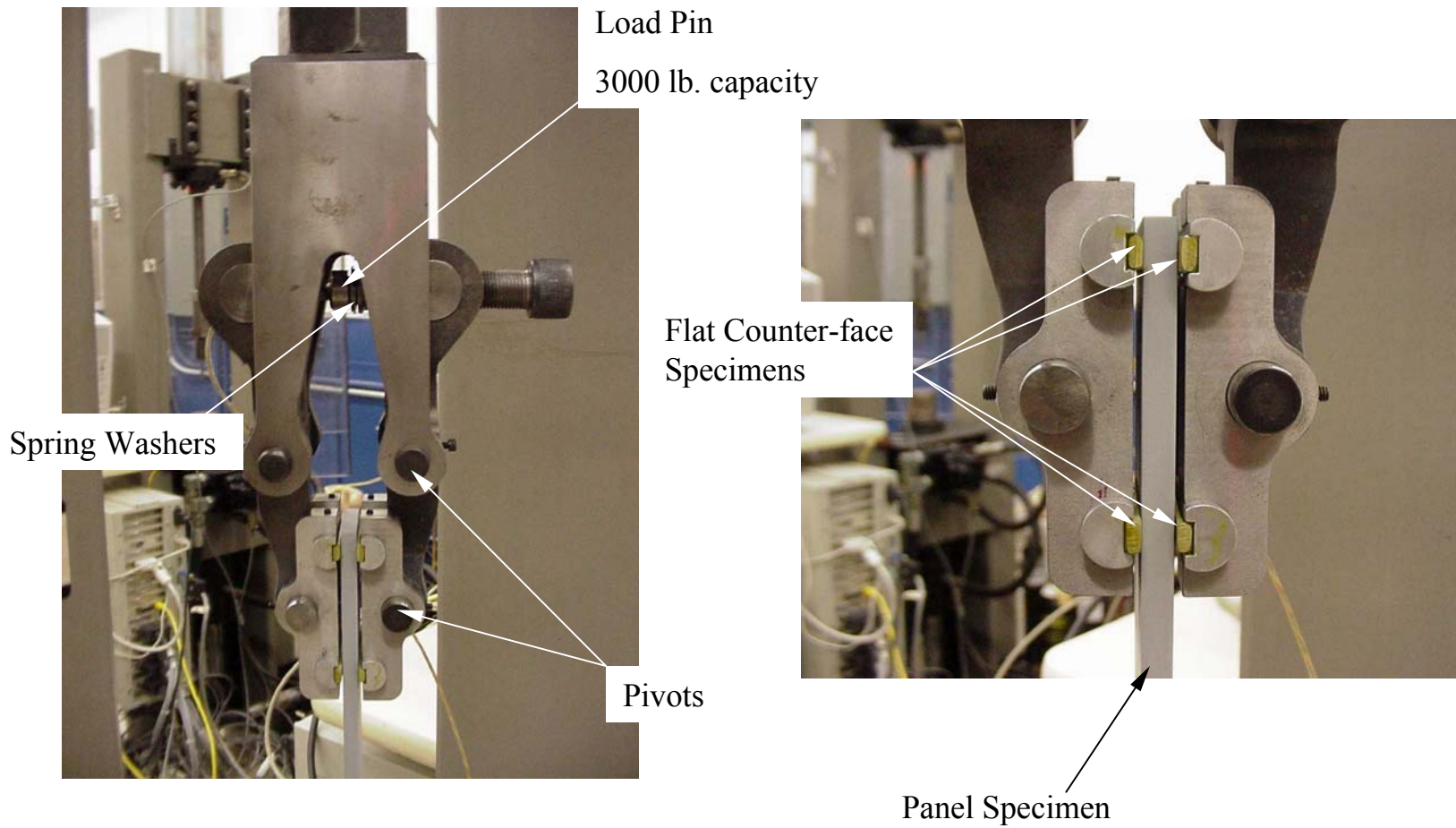

Figure 3-20. Wear Test Assembly With Test Specimens

Steel Wear Rate Comparison Based on Mass Loss Measurements

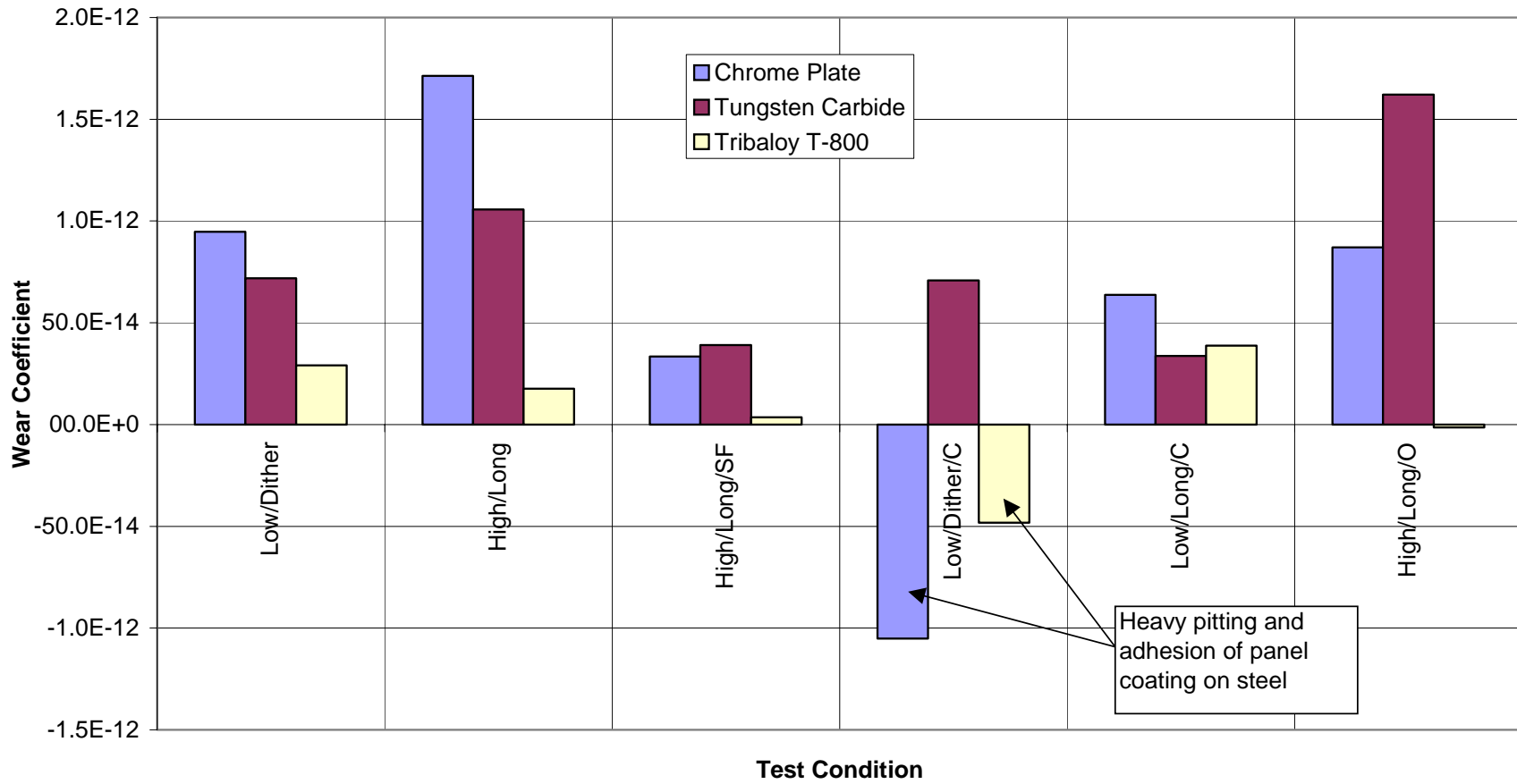

Figure 3-21. Steel Wear Rate Comparison

Panel Wear from Steel Specimens

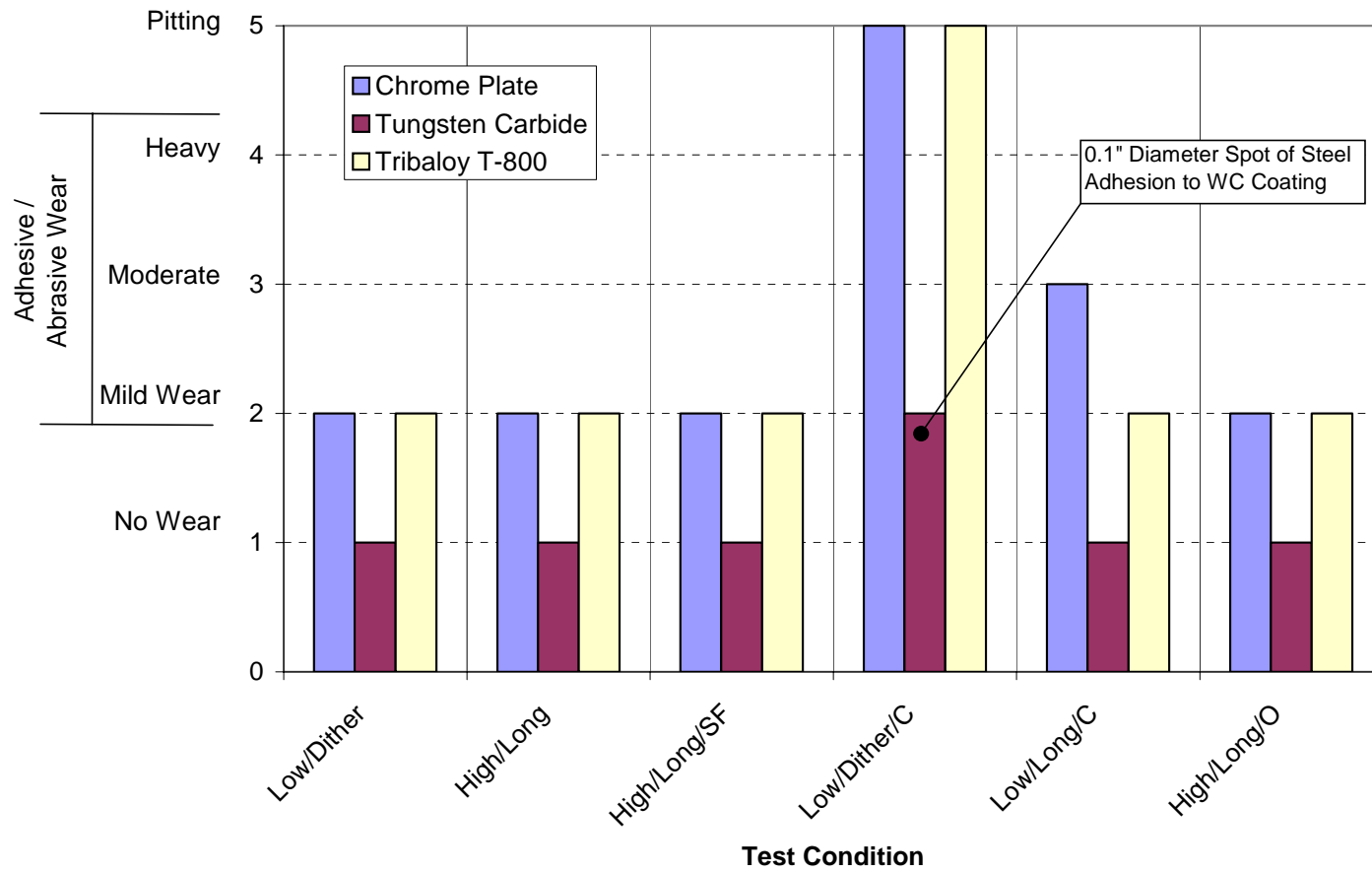

Figure 3-22. Panel Wear From Steel Specimens



Figure 3-23. EHC Dithering in Contaminated Oil With Steel Counter-faces

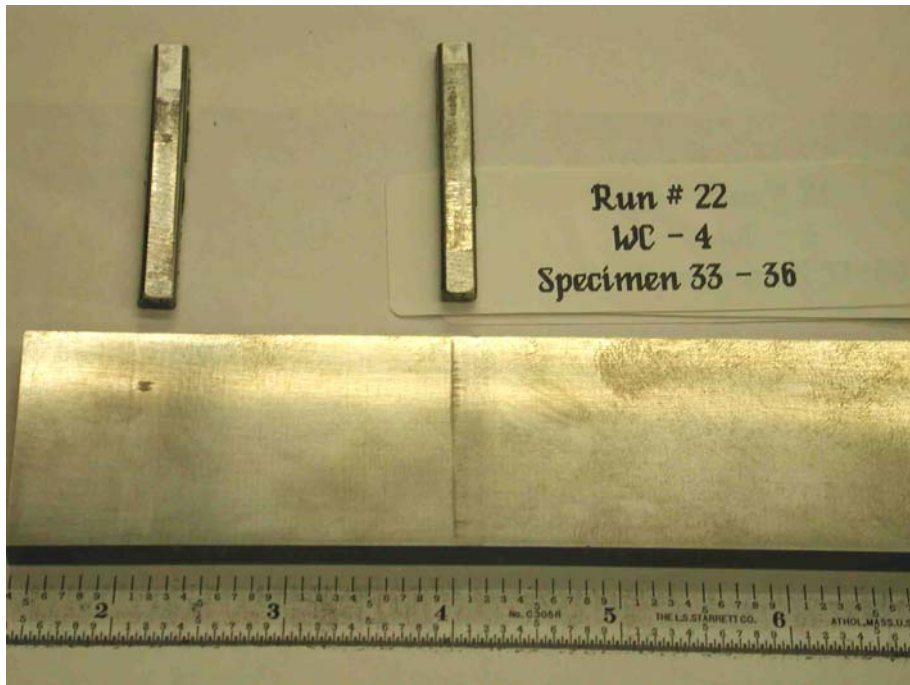

Figure 3-24. WC/Co Dithering in Contaminated Oil with Steel Counter-faces

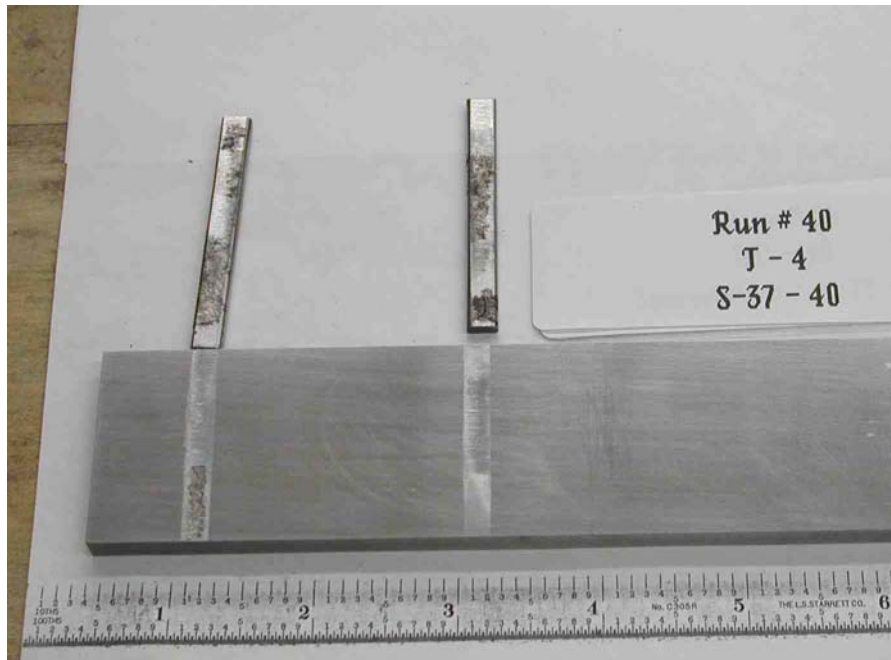

Figure 3-25. T-800 Dithering in Contaminated Oil With Steel Counter-Faces

Copper Wear Rate Comparison Based on Mass Loss Measurements

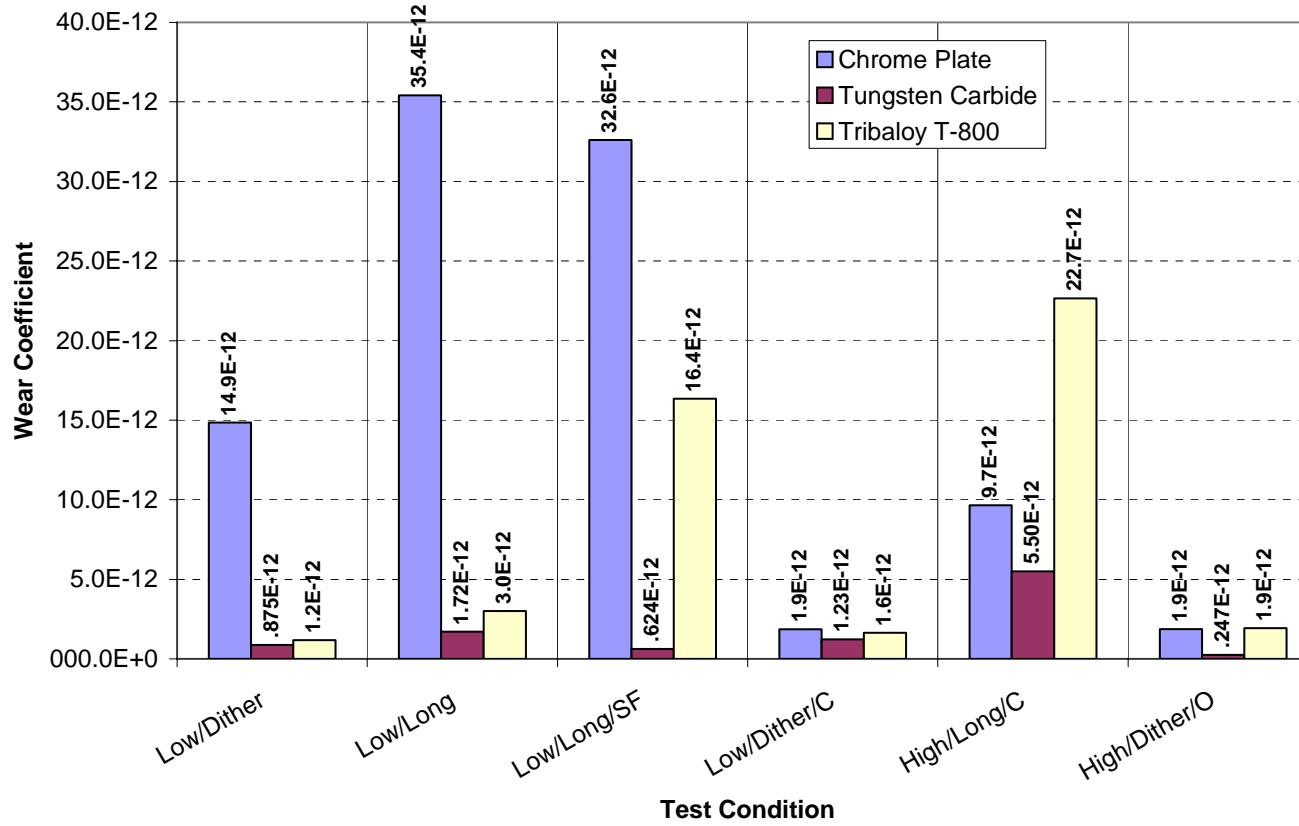

Figure 3-26. Copper Wear Rate Comparison

Panel Wear from Copper Specimens

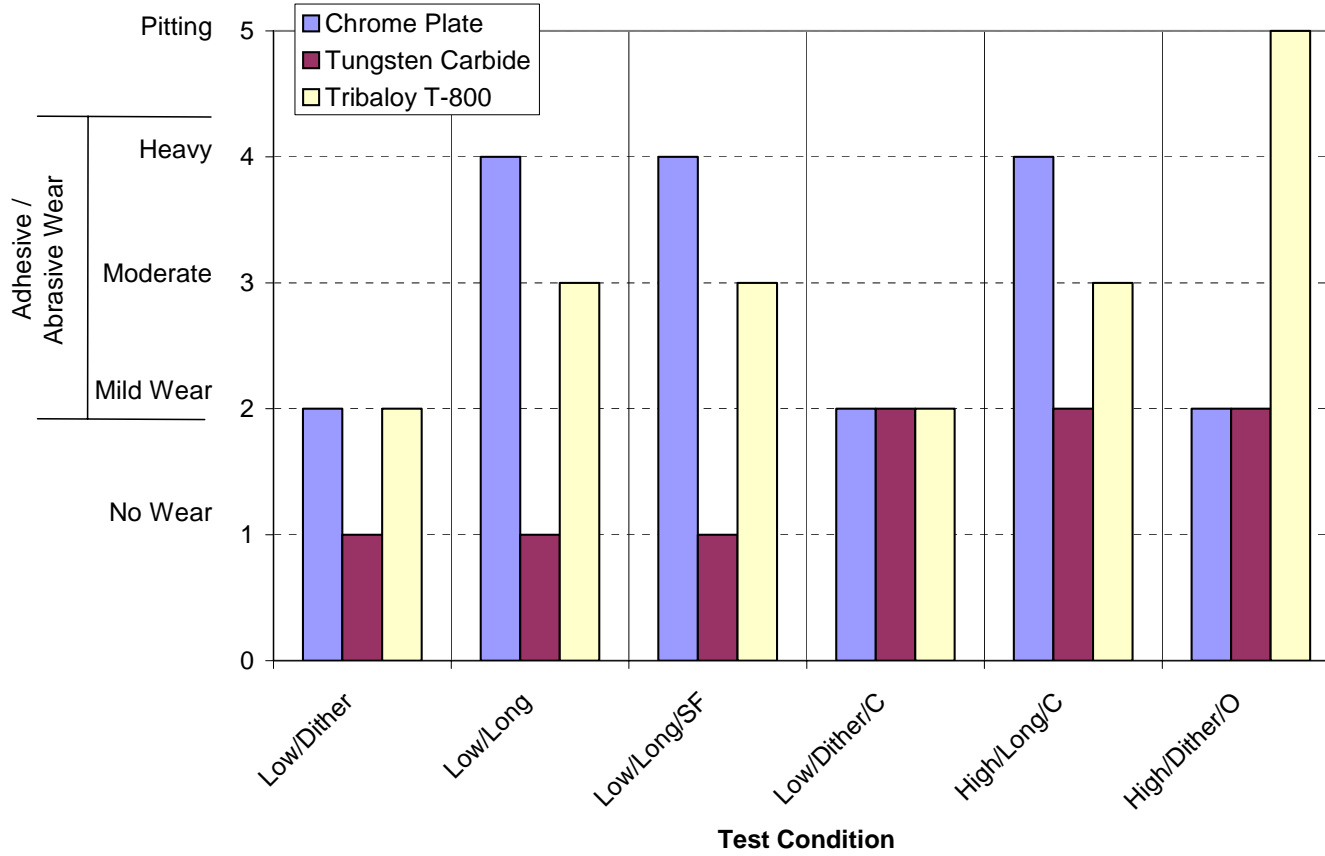

Figure 3-27. Panel Wear From Copper Specimens

Panel Wear Rate Coefficient Against Copper Counterfaces Based on Wear Scar Profilometer Measurements

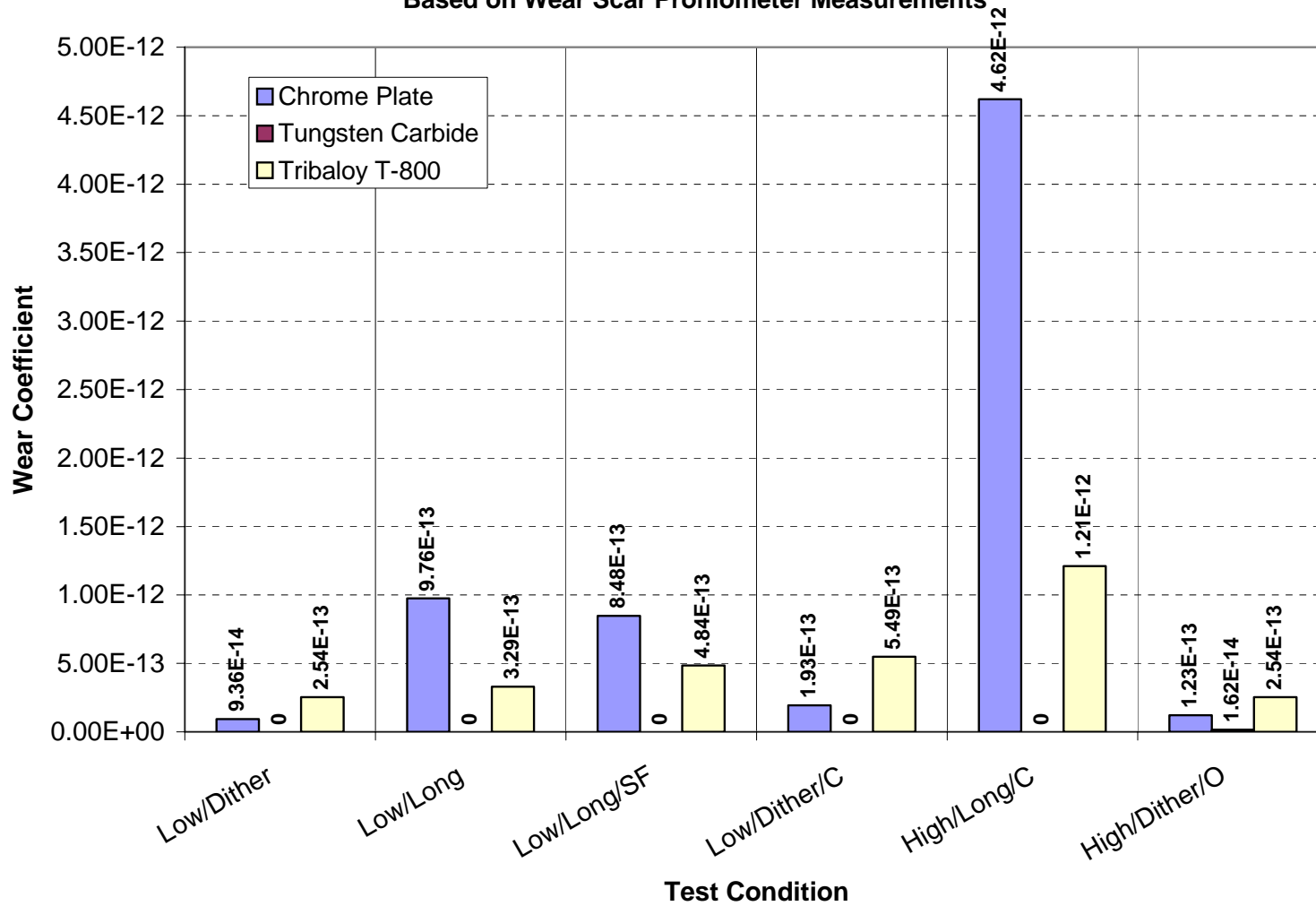

Figure 3-28. Panel Wear Rate Coefficient Against Copper Counter-Faces

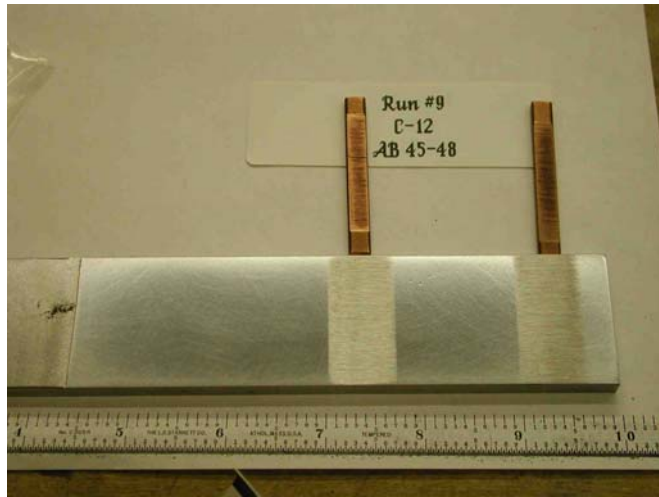

Figure 3-29. EHC Reciprocating Against Copper Counter-Faces



Figure 3-30. WC/Co Reciprocating Against Copper Counter-Faces

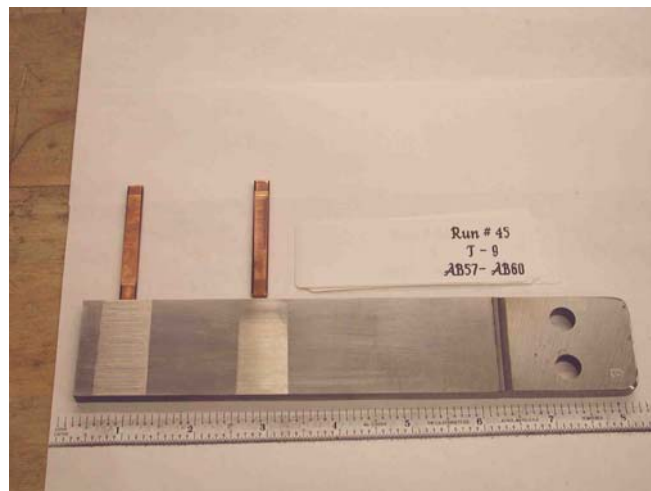

Figure 3-31. T-800 Reciprocating Against Copper Counter-Faces

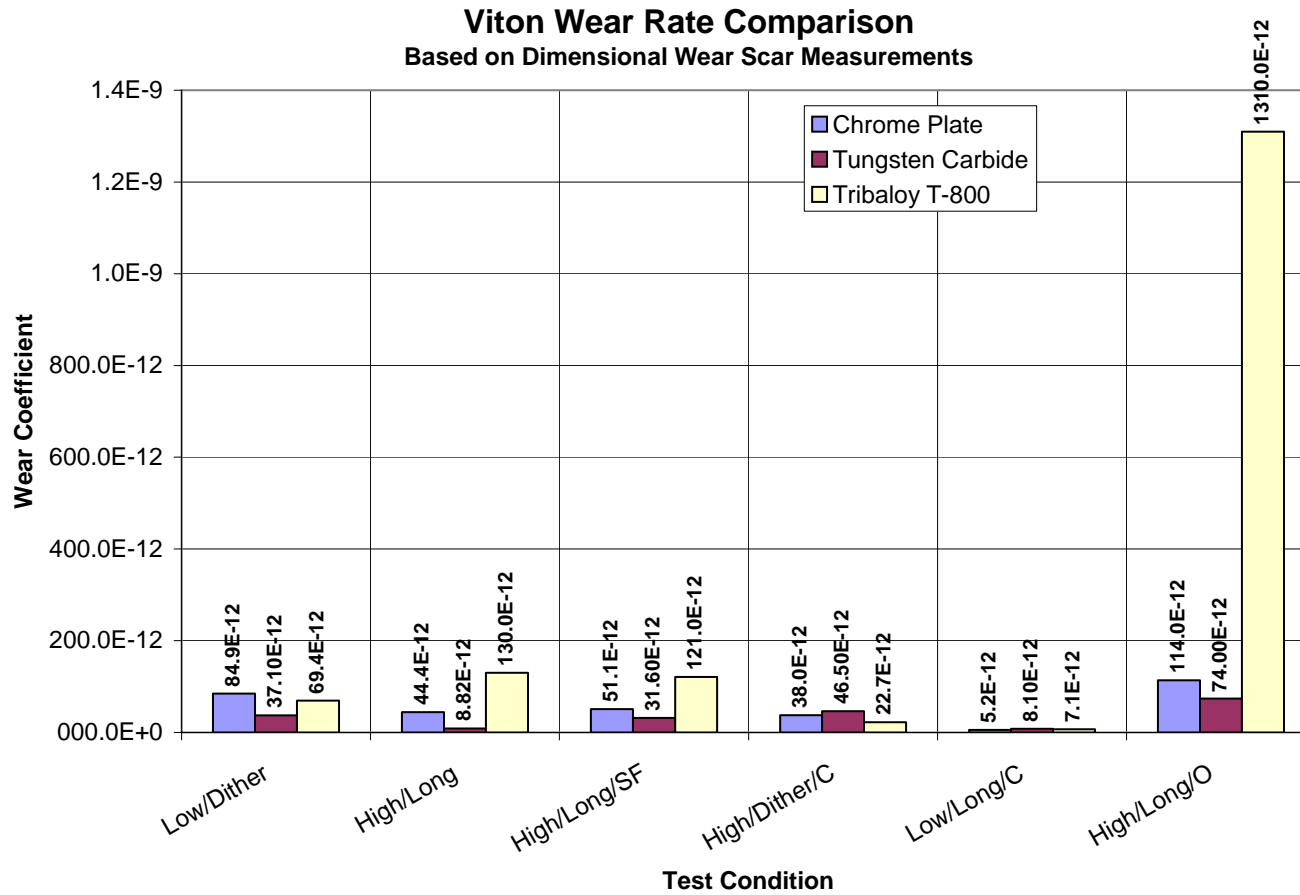

Figure 3-32. Viton Wear Rate Comparison

Panel Wear from Viton Specimens

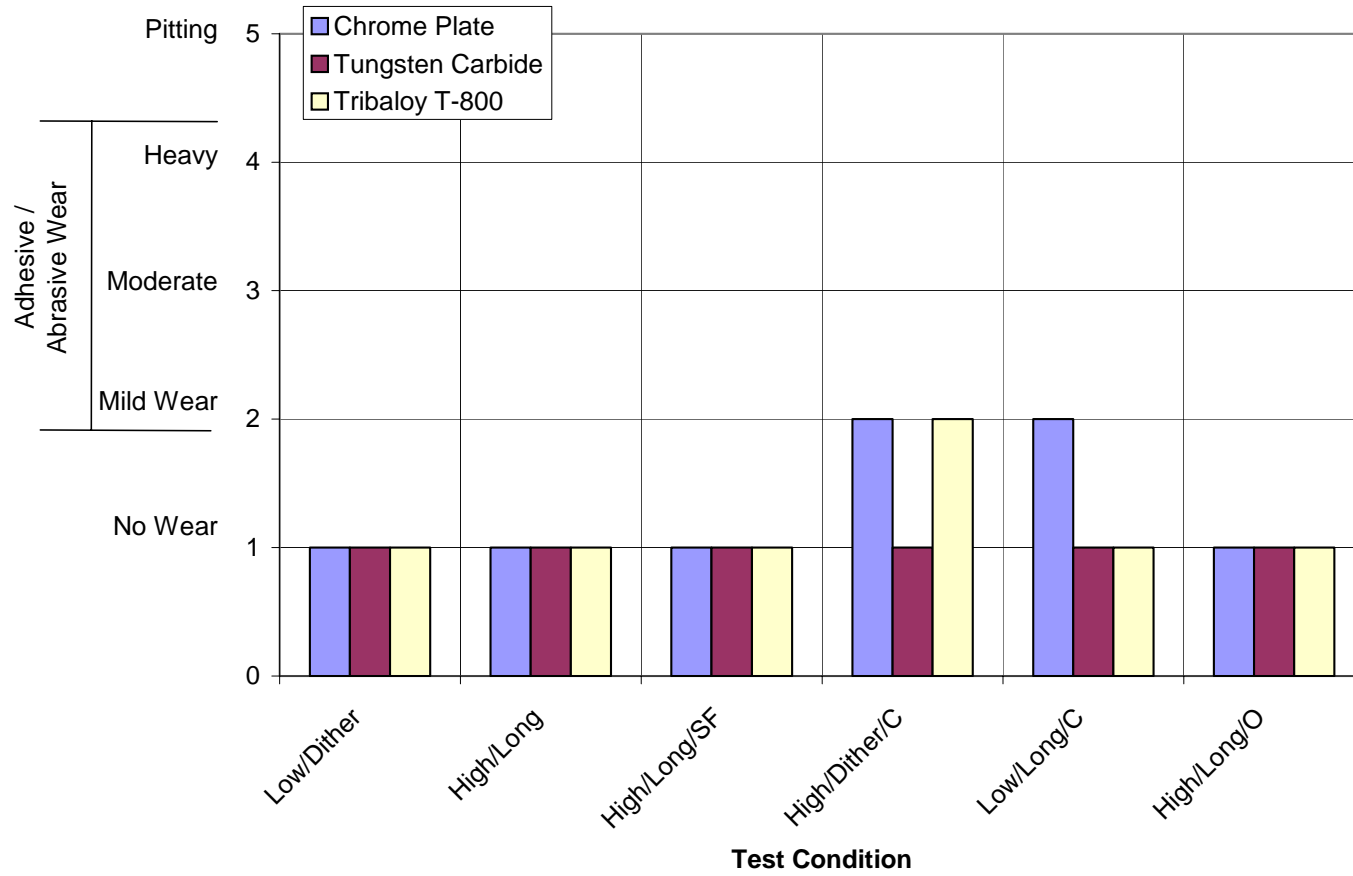

Figure 3-33. Panel Wear From Viton Specimens

PTFE Wear Rate Comparison Based on Mass Loss Measurements

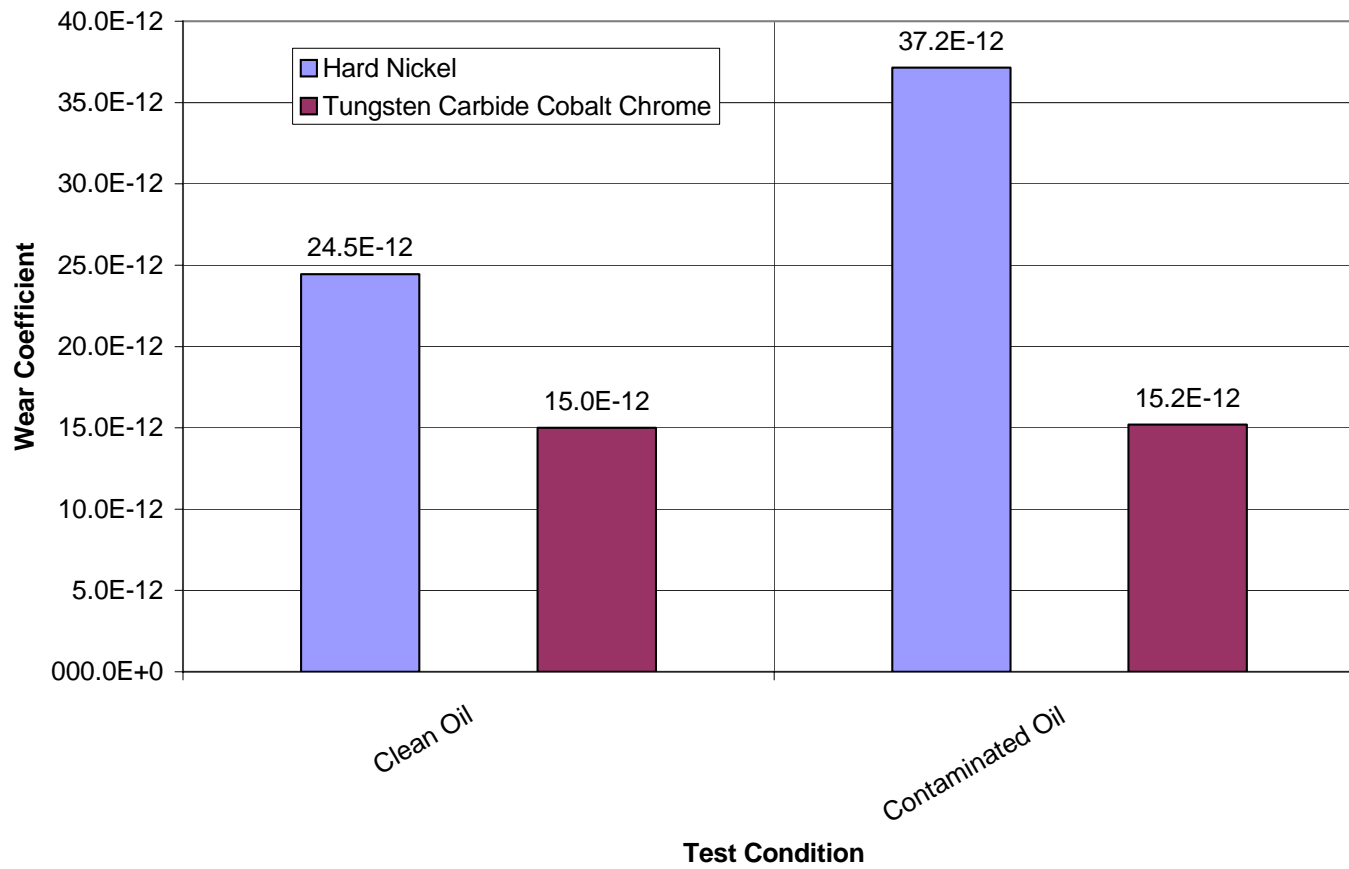

Figure 3-34. PTFE Wear Rate Comparison

Panel Wear from PTFE Specimens

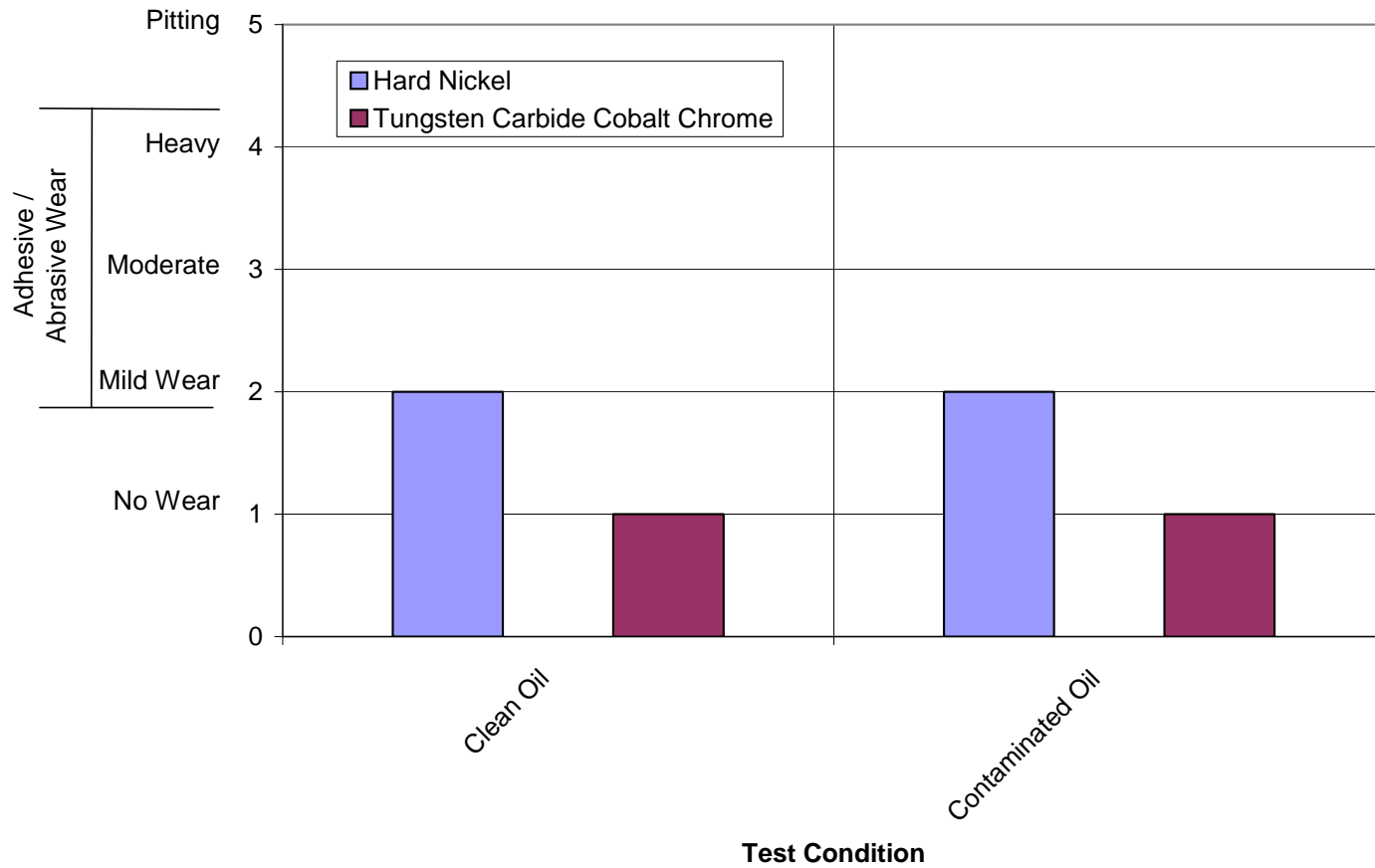

Figure 3-35. Panel Wear From PTFE Specimens

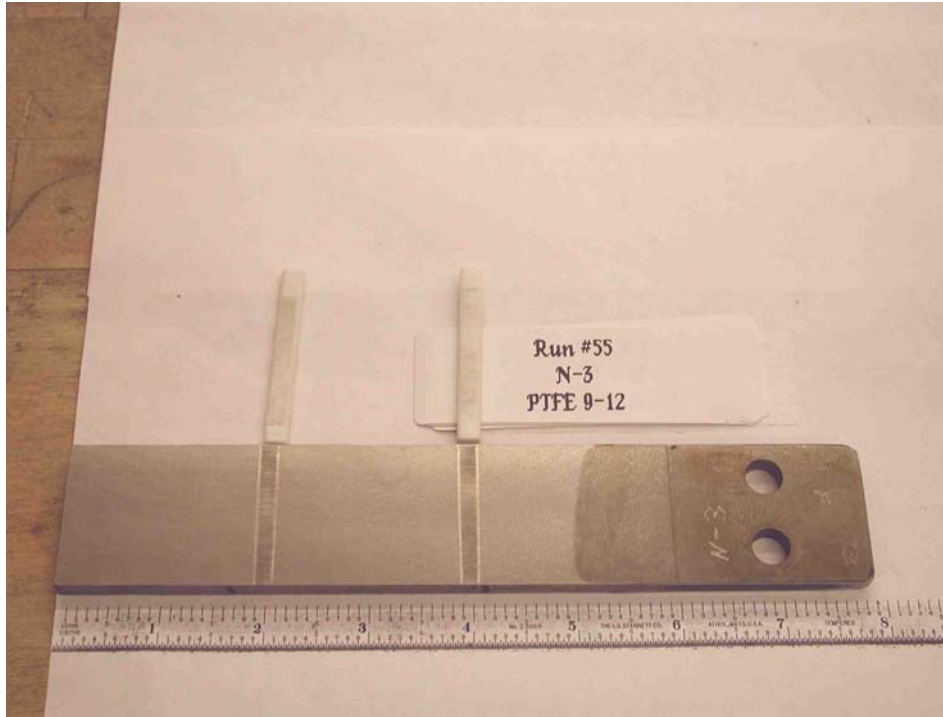

Figure 3-36. Electrolytic Hard Nickel Plate Dithering Against 15% Glass Filled PTFE Counter-Faces

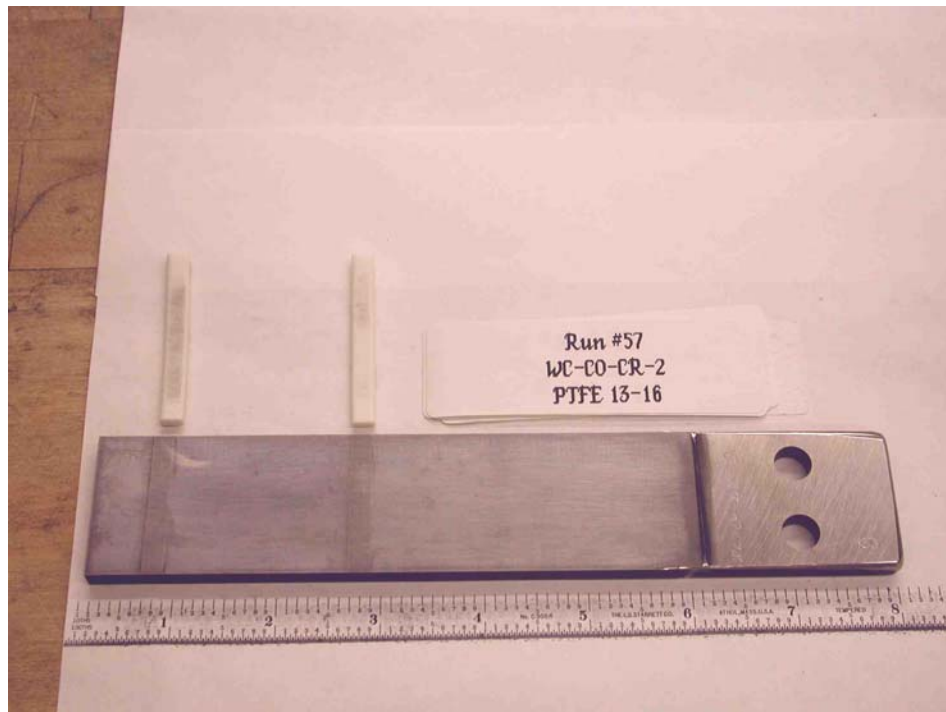

Figure 3-37. WC/CoCr HVOF Coating Dithering Against 15% Glass Filled PTFE Counter-Faces

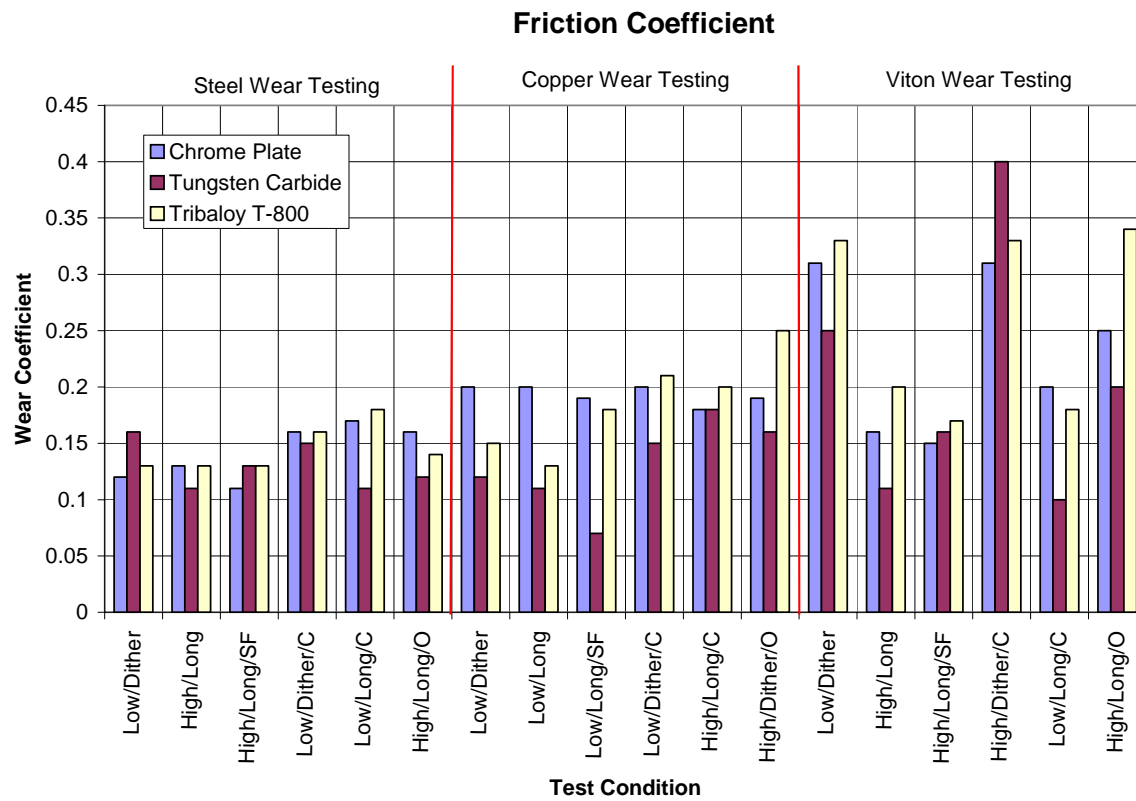

Figure 3-38. Friction Coefficients

PTFE Friction Coefficient Comparison

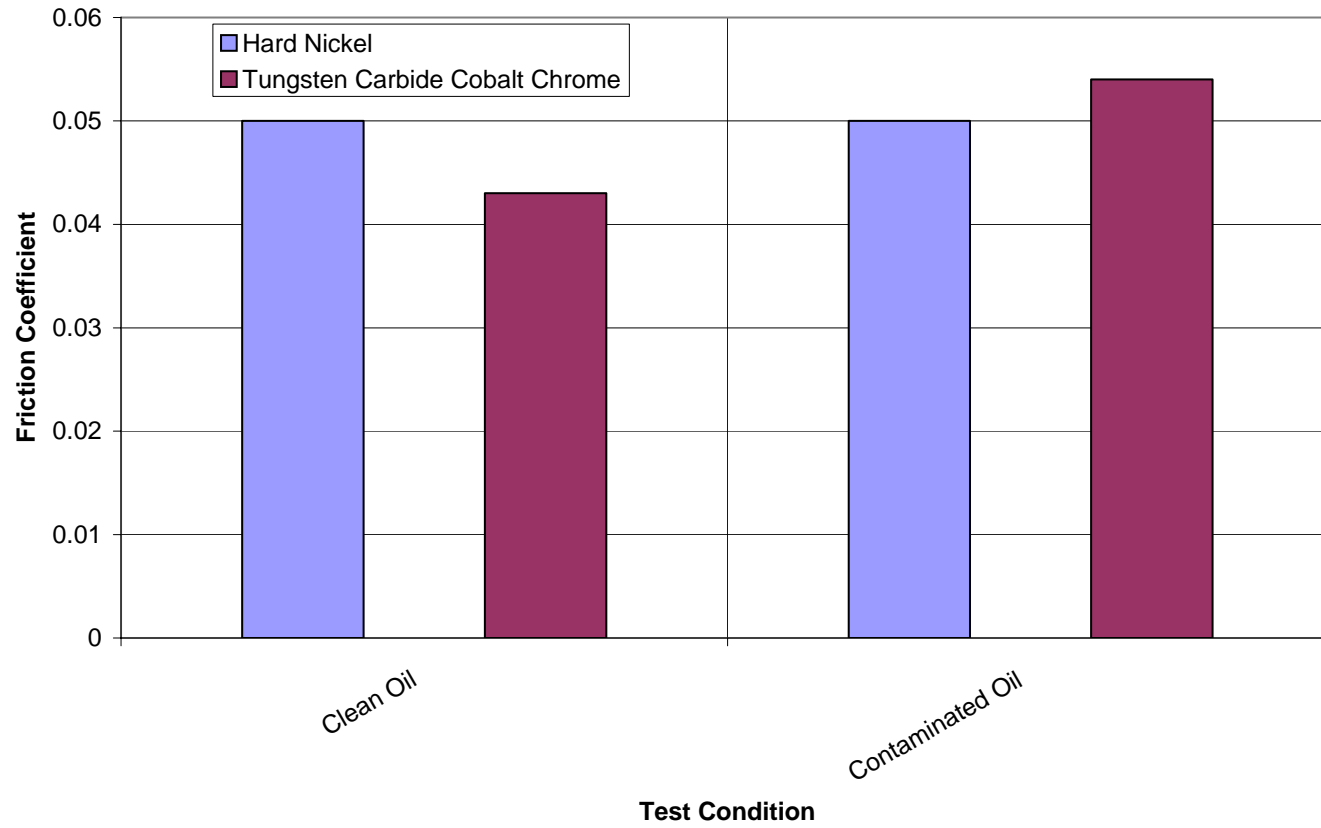

Figure 3-39. PTFE Friction Coefficient Comparison

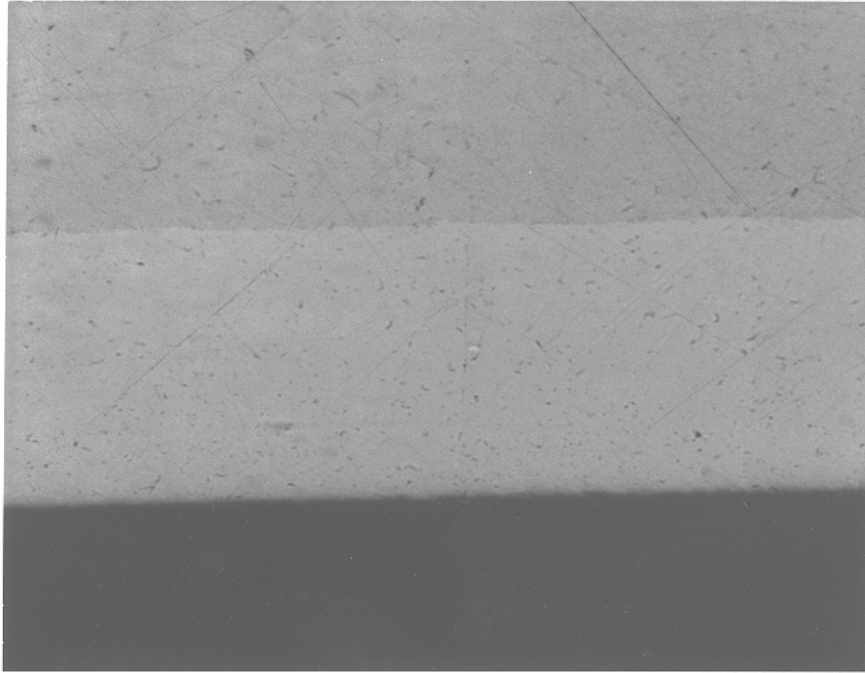

Figure 3-40. Electrolytic Hard Chrome, 500X Magnification

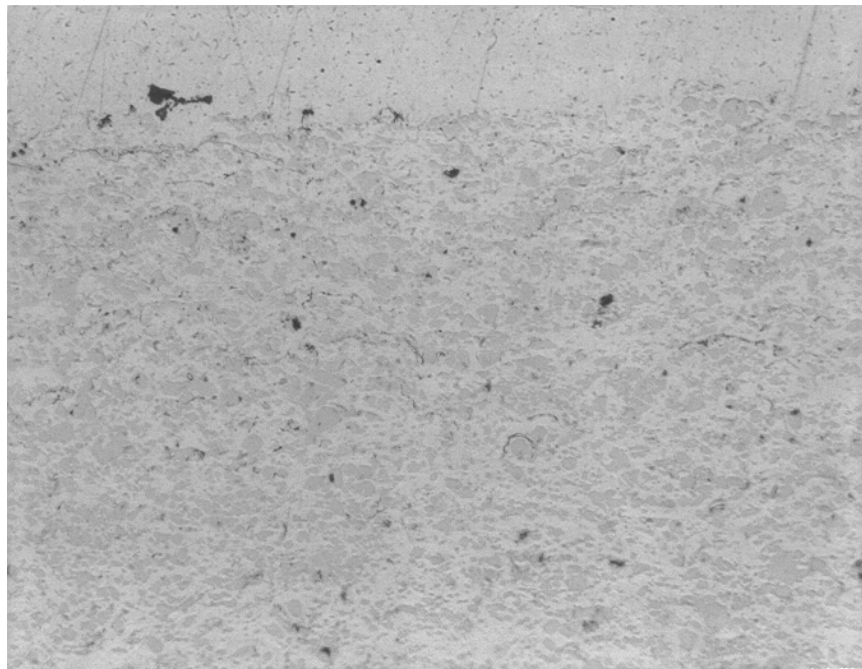

Figure 3-41. HVOF WC/Co, 500X Magnification

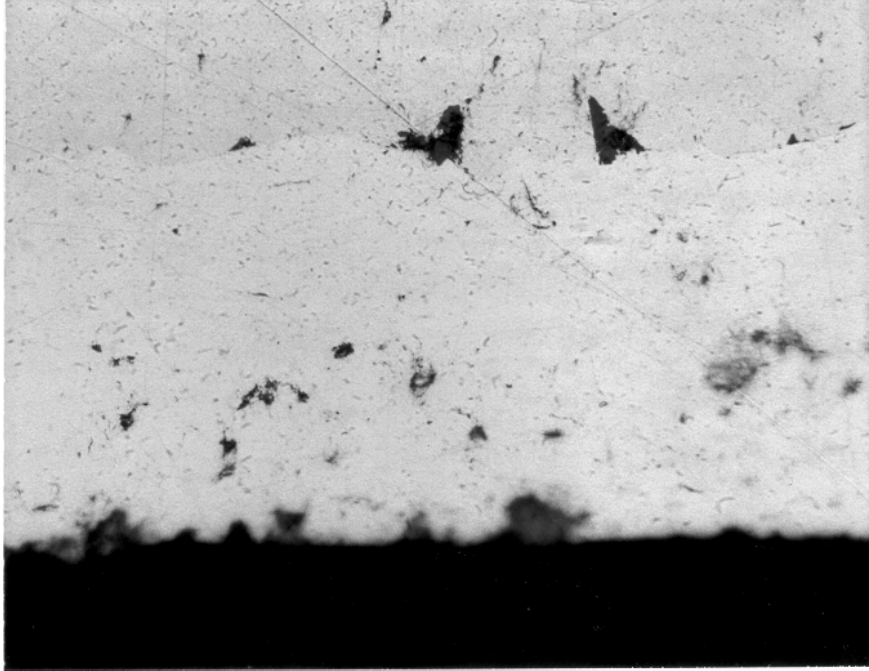

Figure 3-42. HVOF Tribaloy T-800, 500X Magnification

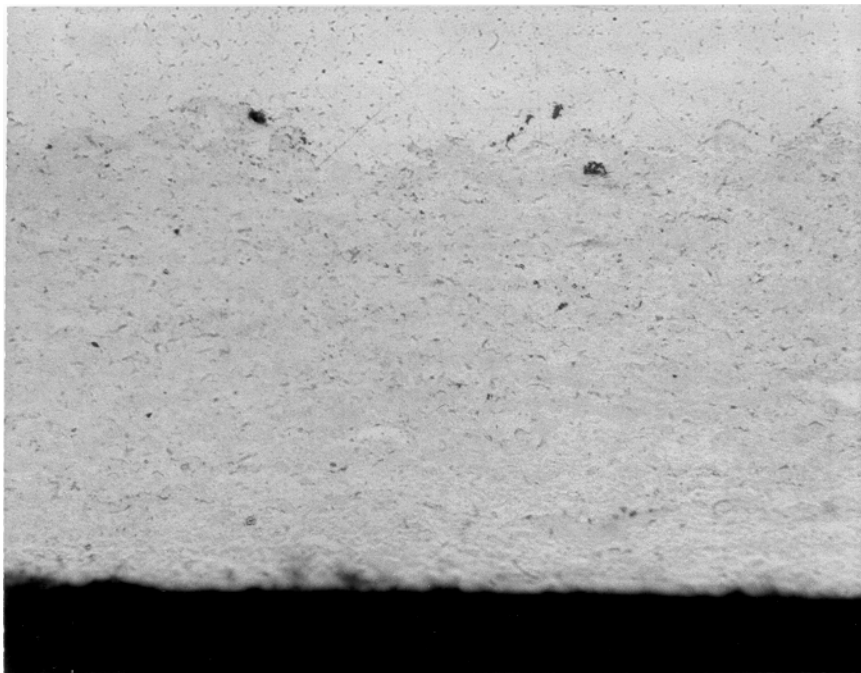

Figure 3-43. HVOF WC/CoCr, 500X Magnification

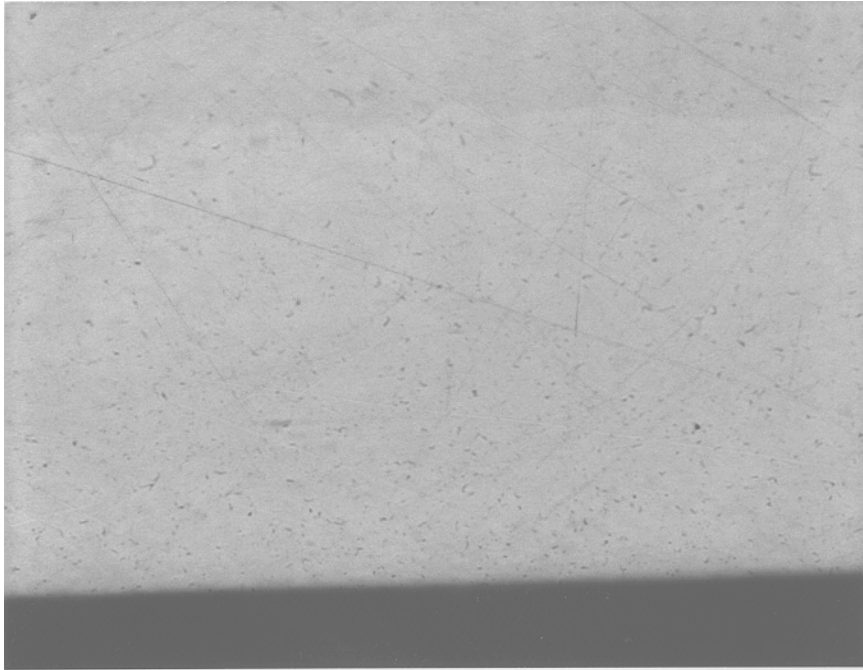

Figure 3-44. Electrolytic Hard Nickel Plate, 500X Magnification

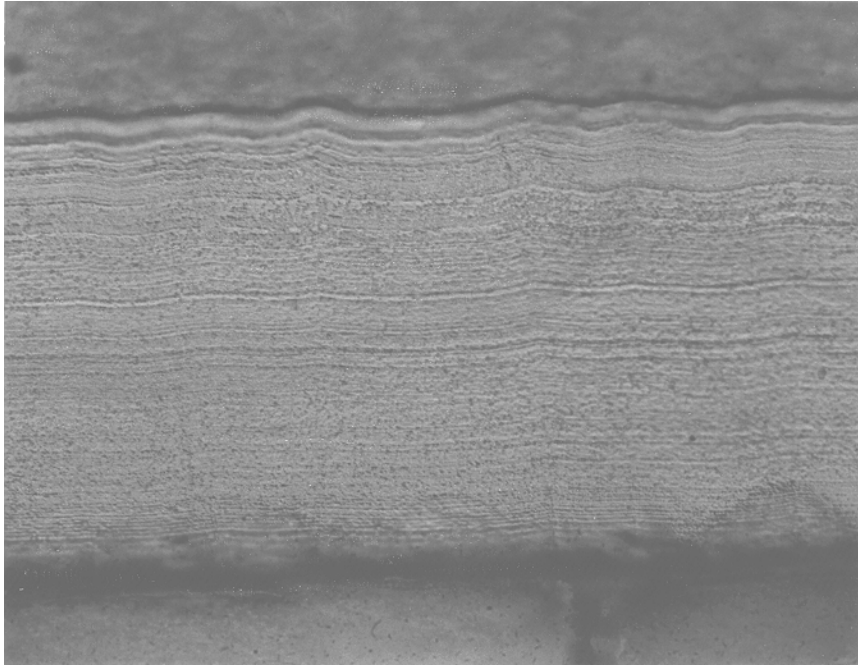

Figure 3-45. Electrolytic Hard Nickel Plate, 500X Magnification, Etched With 50% Nitric / 50% Acetic Acid for 1-2 Seconds

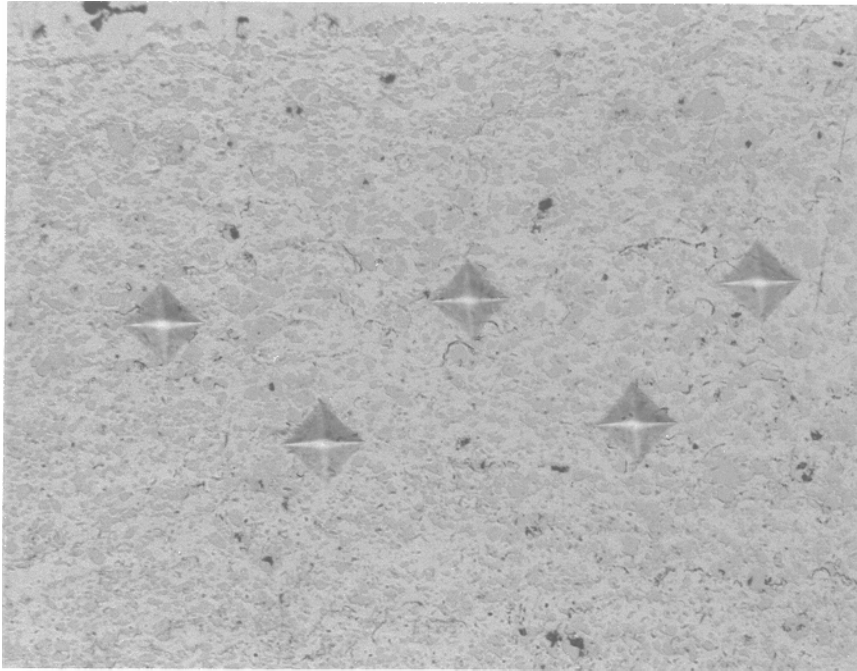

Figure 3-46. 300 Gram Vickers Hardness Impressions on HVOF WC/Co

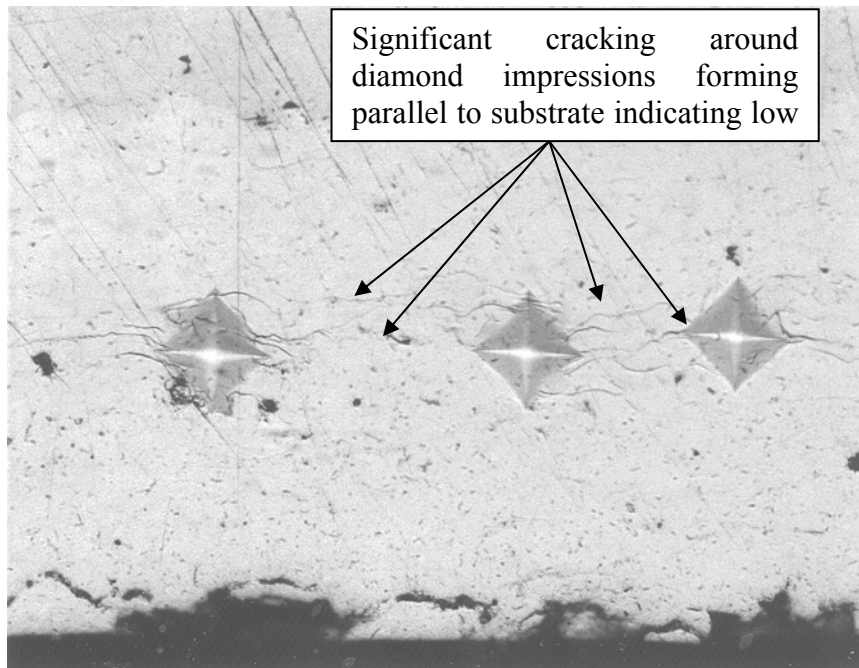

Figure 3-47. 300 Gram Vickers Hardness Impressions on HVOF Tribaloy T-800

3.6. Toxicity Characteristic Leaching Procedure (TCLP)

3.6.1. Introduction

TCLP testing was performed to determine if production scrap, waste or used components coated with WC/Co Cr (WCCoCr), Tribaloy 400 and Tribaloy 800 should be classified as hazardous waste by the U.S. Environmental Protection Agency (EPA) and therefore regulated under 40 CFR Part 261 Subpart C.

3.6.2. Findings

The test results of the raw and spent powder samples of WC/CoCr, Tribaloy T-400 and Tribaloy T-800 (shown in Table 3-7) gave no indication that they were above the regulatory level for chrome or nickel. Based on the results, these materials will not be classified as hazardous waste by the EPA. In Connecticut, however, the waste would be classified under non-hazardous regulated waste and would need to be properly collected and disposed.

3.6.3. Discussion

TCLP testing was conducted in accordance with Plan of Test #54HPT-57 (see the appendix to the JTR [3.3]). The test plan was written in accordance with EPA method 1311. HS subcontracted the TCLP evaluation to two independent laboratories so that results could be compared and validated. Environmental Science Corporation performed testing on spent and virgin powders provided by Sulzer Metco Incorporated. The results were verified by Katahdin Analytical Services and were as follows:

Table 3-7 . TCLP Test Results

Pretest Condition	Sample	Chromium	Nickel
Spent Solid	T400	0.62 mg/L	0.16 mg/L
	T800	0.41 mg/L	0.07 mg/L
	WC Co Cr	1.00 mg/L	2.92 mg/L
Virgin Powder	T400	0.85 mg/L	0.68 mg/L
	T800	0.34 mg/L	0.20 mg/L
	WC Co Cr	0.76 mg/L	2.14 mg/L

3.7. Component Testing

3.7.1. Introduction

The purpose of the component test was to assess the durability of the WC/17Co HVOF coating on the actual lever support sleeve in a simulated operating environment. The

WC/17Co was selected for component testing based on the favorable results obtained during wear and fatigue testing. The lever support sleeve was assembled into a low-pitch-stop assembly and cycle tested using production test fixturing. The number of actuation cycles selected for the test was based on one standard overhaul life, which was estimated at 75,000 cycles. This was based on the following:

- Propeller time before overhaul (TBO) is 7,500 hours (TBO period established by the Navy for the P-3 propeller system)
- Duration of each flight equals one hour
- Low-pitch-stop is activated 10 times per flight

The low-pitch-stop sleeve ID was measured at approximately every 7,500 cycles. One cycle was counted as the forward and return stroke of the low-pitch-stop piston. The total travel distance of one actuation cycle was approximately 2.06". The low-pitch-stop piston was actuated with a pressure of 310 ± 5 psi.

3.7.2. Test Procedure

Component testing of the WC/17Co and chrome lever sleeves was accomplished using an E-2 propeller low-pitch-stop assembly. Each of the assemblies was installed in the test fixture, Figure 3-48, and actuated using Mil-H-83282 at a pressure of 310 psi. The test stand consisted of a holding fixture, controller, counter and a hydraulic test stand, Figure 3-49. The low-pitch-stop assembly was removed at intervals of approximately 7,500 cycles to facilitate inspection of the actuator bore.

At the conclusion of the testing, measurements were taken of the piston bore and wall thickness as well as the width, thickness and weight of the piston ring. Additionally, a surface reading of the piston bore was taken using the Tokyo Surfacom profilometer, which accurately measured the step height changes in the worn and unworn surfaces.

To ensure that accurate weight loss measurements were recorded for the piston ring, the ring was presoaked in the MIL-H-83282 under vacuum conditions. The purpose of this was to saturate the ring with hydraulic fluid by filling the surface porosity. Porosity is a natural result of the casting process used to produce the copper-based piston ring.

3.7.3. Results

Upon completion of testing, both the low-pitch-stop sleeves and piston rings were visually examined, measured and surface finish readings taken. The piston rings were also weighed in an attempt to quantify the amount of wear. Table 3-8 shows the average readings taken during testing of the low-pitch-stop sleeve ID and piston ring. The wear to the inside diameter was quite minimal and in some cases showed a slight increase in size. This was due to the imprecision in the repeatability of measurement using the Cordax RS-70DCC coordinate measuring machine.

Visually, the ID of the WC/17Co sleeve appeared unworn whereas the chrome sleeve showed some initial signs of wear. The wear was minimal and no significant indications of adhesive wear or scoring were present (see Figure 3-50). The piston rings against the WC/17Co and chrome sleeves also showed signs of wear, though not significant. Weight measurements of the piston rings before and after test showed that weight loss was three

times higher running on the chrome sleeve.

Surface measurements taken of the WC/17Co sleeve confirmed the visual results. Pre- and post-test surface finish measurement gave the same reading of 7.2 microinches Ra. The final surface finish measurements of the ID of the chrome sleeve confirmed that surface wear had occurred. At the start of the test the surface roughness of the chrome sleeve was measured at 2.7 microinches Ra. The surface roughness at the conclusion of testing was measured at 1.4 microinches Ra.

Table 3-8 . Dimensional Data for Low-Pitch-Stop Sleeve and Piston Ring During Testing

Chrome Data (Baseline)						WC-17Co Data					
Cycles	0	10,500	22,500	37,500	Delta	Cycles	0	10,000	22,500	37,800	Delta
ID Sleeve (538889)	4.2494	4.2495	4.2496	4.2494		ID Sleeve (538889)	4.2509	4.2506		4.2504	
Delta		-5E-05	-1.67E-04	3.33E-05		Delta		3.50E-04		2.00E-04	
Wall Thickness (adjacent to threads)	0.098			0.0977	1.33E-04	Wall Thickness (adjacent to threads)	0.100			0.102	-2.33E-03
Surface Finish (Ra)	2.7			1.4		Surface Finish (Ra)	7.2			7.2	

Ring (537857)					Delta	Ring (537857)					Delta
Width (inside/outside)	0.172			0.1733	-0.001	Width (inside/outside)	0.1715			0.1780	-0.006
Thickness (top/bottom)	0.123			0.1212	0.002	Thickness (top/bottom)	0.1214			0.1246	-0.003
Soaked Weight (grams)	40.5848			40.5498	0.035	Soaked Weight (grams)	40.746			40.7350	0.011

* Chrome testing time frame 5/24/2001 thur 8/15/2001

*WC-17Co testing time frame 8/28/2001 thur 10/09/2001

3.7.4. Conclusions

At the conclusion of the testing, both lever sleeves were visually inspected. Both the chrome and WC/17Co sleeves appeared to be in good condition. The chrome showed evidence of polishing while the WC/17Co looked untouched.

- Post-test surface finish measurements taken of both piston bores revealed that the chrome-plated bore had a finer finish aft and the WC/17Co remained unchanged.
- Piston ring wear was lower against the WC/17Co than the chrome.

3.7.5. Recommendations

Based on the test results, Hamilton Sundstrand recommends WC/17Co as a replacement for chrome plate on the ID of the low pitch stop lever sleeve for the 54460 and 54H60 applications. Wear of the HVOF coating in a simulated operating environment was less than the baseline chrome. The HVOF-coated bore produced less wear on the mating piston ring than did the chrome-plated bore.

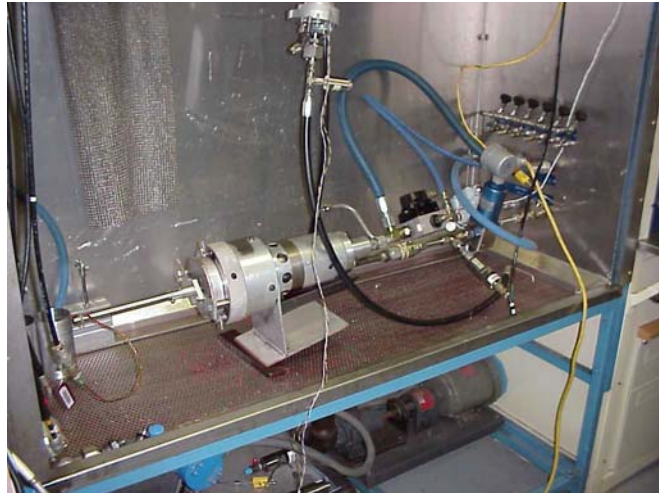

Figure 3-48. Low-Pitch-Stop Sleeve Testing Fixture

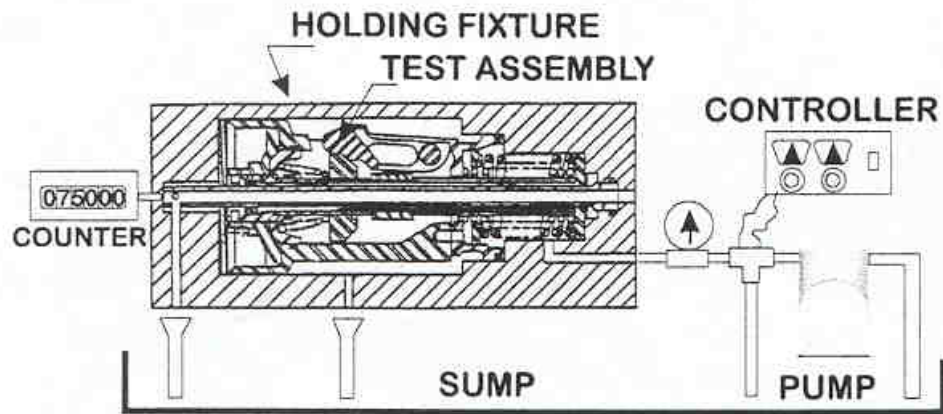

Figure 3-49. Low-Pitch-Stop Sleeve Testing Fixture Schematic



Chrome Sleeve



Piston Ring from Chrome Sleeve



WC-17Co Sleeve

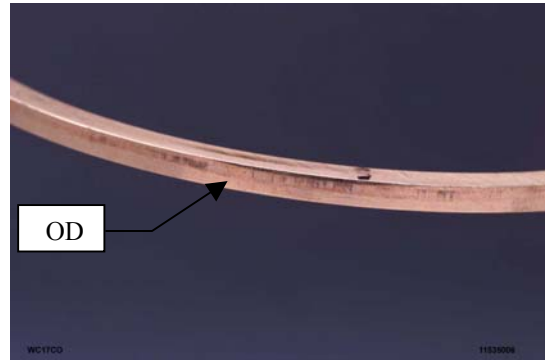

Piston Ring from WC-17Co

Figure 3-50. Low-Pitch-Stop Sleeves and Piston Rings After Testing

3.8. References

- 3.1 “Joint Test Protocol, Validation of WC/Co, WC/CoCr and Tribaloy 800 HVOF Thermal Spray Coatings as a Replacement for Hard Chrome Plating on C-2/E-2/P-3 and C-130 Propeller Hubs and Low Pitch Stop Sleeve.” Prepared by Hard Chrome Alternatives Team for Environmental Security Technology Certification Program, November 1999.
- 3.2 Hamilton Sundstrand Materials Engineering memo MM-02-04
- 3.3 Joint Test Report. “Validation of HVOF WC/Co, WC/CoCr and Tribaloy 800 Thermal Spray Coatings as a Replacement for Hard Chrome Plating on C-2/E-2/P-3 and C-130 Propeller Hubs and Low Pitch Stop Lever Sleeve”, HCAT, 15 October 2002. Hamilton Sundstrand Report HSER 22384.

This page intentionally left blank.

4. Cost Benefit Analysis

4.1. Introduction

The Joint Logistics Commanders (JLC) and Headquarters National Aeronautics and Space Administration (NASA) co-chartered the Joint Group on Pollution Prevention (JG-PP) to coordinate joint service/agency activities affecting pollution prevention issues identified during system and component acquisition and sustainment processes. The primary objectives of the JG-PP are to:

- Reduce or eliminate the use of hazardous materials (HazMats) at manufacturing, remanufacturing and sustainment locations
- Avoid duplication of efforts in actions required to reduce or eliminate HazMats through joint service cooperation and technology sharing.

JG-PP projects typically involve an original equipment manufacturer (OEM) producing multiple defense systems for more than one of the Services, as well as at least one depot servicing one or more of the defense systems. JG-PP technical representatives for each project begin by selecting a target HazMat for reduction or elimination and identifying alternative technologies or materials for evaluation. A cost benefit analysis (CBA) can be performed before or after alternative technologies are agreed upon. A CBA, which is performed using the JG-PP *Cost Benefit Analysis (CBA) Methodology*, dated June 30, 1998 [4.1], reports the estimated financial impact of implementing these alternatives. The JG-PP CBA Methodology is based on the Environmental Cost Analysis Methodology (ECAM) described in the *Environmental Cost Analysis Methodology (ECAM) Handbook*, dated March 29, 1999 [4.2].

Hexavalent chromium that is electroplated onto propeller hubs was identified as a target HazMat to be eliminated or reduced. WC/Co applied by the high-velocity oxygen-fuel (HVOF) thermal spray process is being considered as a potential alternative to hard chrome electroplating as part of this project.

To quantify the economic feasibility of implementing HVOF WC/Co at a Department of Defense (DoD) facility, a CBA was performed focusing on an actual facility that conducts repairs on propeller hub components. This facility is considering implementation of HVOF equipment that has been installed for Environmental Security Technology Certification Program (ESTCP) demonstration and validation. The ESTCP, which is managed by the Office of the Deputy Undersecretary of Defense for Environmental Security, demonstrates and validates laboratory-proven technologies that target the most urgent environmental needs of DOD.

Information about current hard-chrome electroplating operations at the facility was used to estimate the economic impact that may be expected if some hard-chrome electroplating is replaced by HVOF WC/Co. The results of this CBA are intended to assist OEMs and DoD facilities in decisions related to replacing hard-chrome electroplating.

4.2. Approach

Data collection at the repair/overhaul facility and financial analyses of the data were performed using the JG-PP CBA Methodology. In accordance with this methodology, baseline process flow diagrams associated with current hard-chrome electroplating processes were developed (refer to Figure 4-1). This generic flow diagram is based on information provided by the facility prior to collection of the process data.

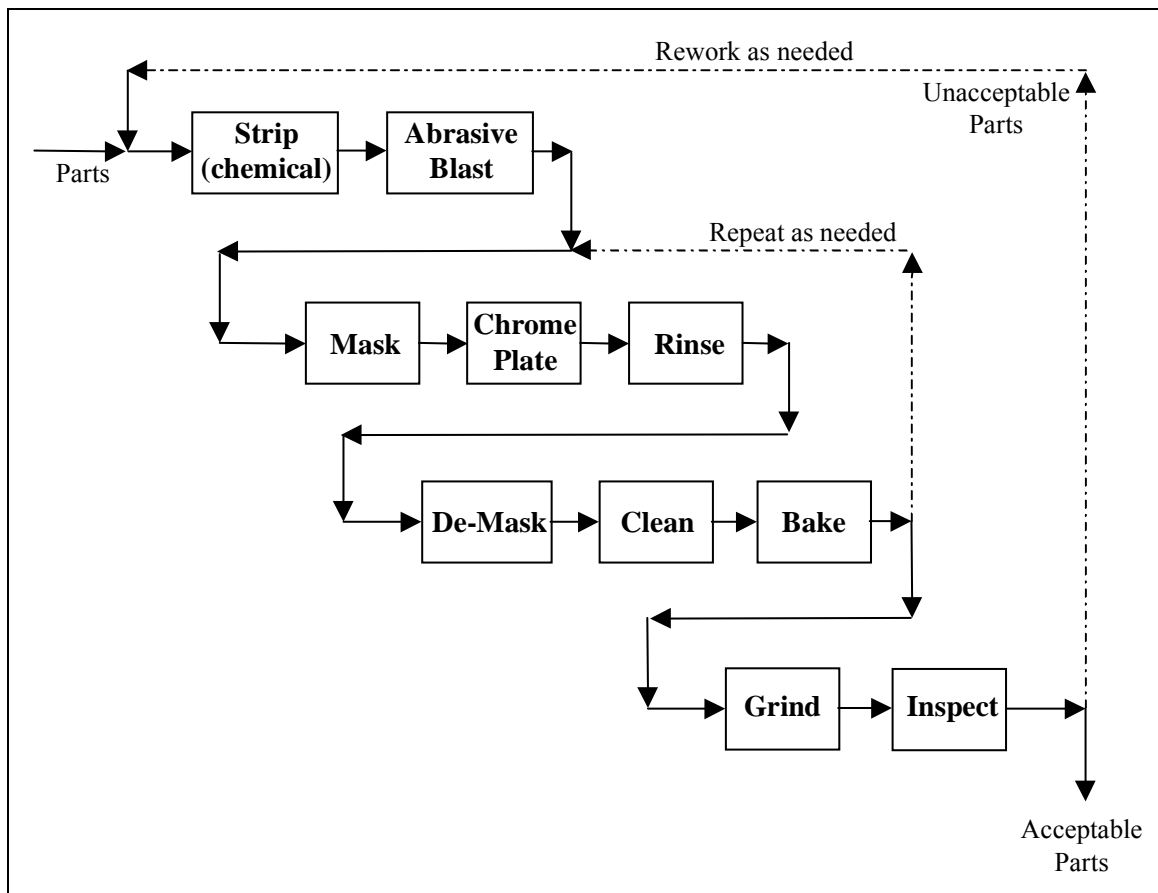

Figure 4-1. Process Flow of Hard-Chrome Electroplating

Data collection forms were developed and a site visit was performed to collect information on the baseline hard-chrome electroplating operations at the facility. Information was collected in accordance with the JG-PP CBA Methodology and the approach outlined in the *Environmental Cost Analysis Methodology Implementation Report, Appendix 4 of 5: Naval Aviation Depot at Jacksonville, Florida* (dated January 7, 1998) [4.3]. During the site visit, interviews were held with plating engineers, operators, chemists and supervisors; environmental engineers; the environmental management team; safety personnel; and other employees throughout the facility. The information gathered during the site visit was supplemented with correspondence after the visit. Where available, material usage rates and costs, labor hours, and waste treatment and disposal costs were identified. Where data were not available, values were assumed based on data

from other facilities and using engineering judgment (see Section 4.3.1).

Environmental, safety, and occupational health (ESOH) activity costs were also obtained where available, or estimated. Some costs that may be associated with ESOH activities are listed below.

- Creating and maintaining Material Safety Data Sheets (MSDSs)
- Lost productivity from worker exposure to the HazMats associated with hard-chrome electroplating and from the use of personal protective equipment (PPE)
- Maintaining an accumulation point for waste
- Preparing container labels and manifest forms for hazardous waste
- Providing and administering environmental and operational training
- Purchasing and maintaining PPE
- Purchasing and storing drums, labels and shipping materials associated with waste.

The collected operating information was used to estimate the potential financial impact of the project, in accordance with the JG-PP CBA Methodology. A process flow diagram relating to the application of WC/Co by HVOF was also developed to aid in analysis of the data. A generic process flow diagram for HVOF WC/Co is shown in Figure 4-2. As with Figure 4-1, rework steps are included because aircraft propeller hubs may be processed more than once to achieve desired coating thickness on specific areas of each component, and because some components may be improperly coated and require rework.

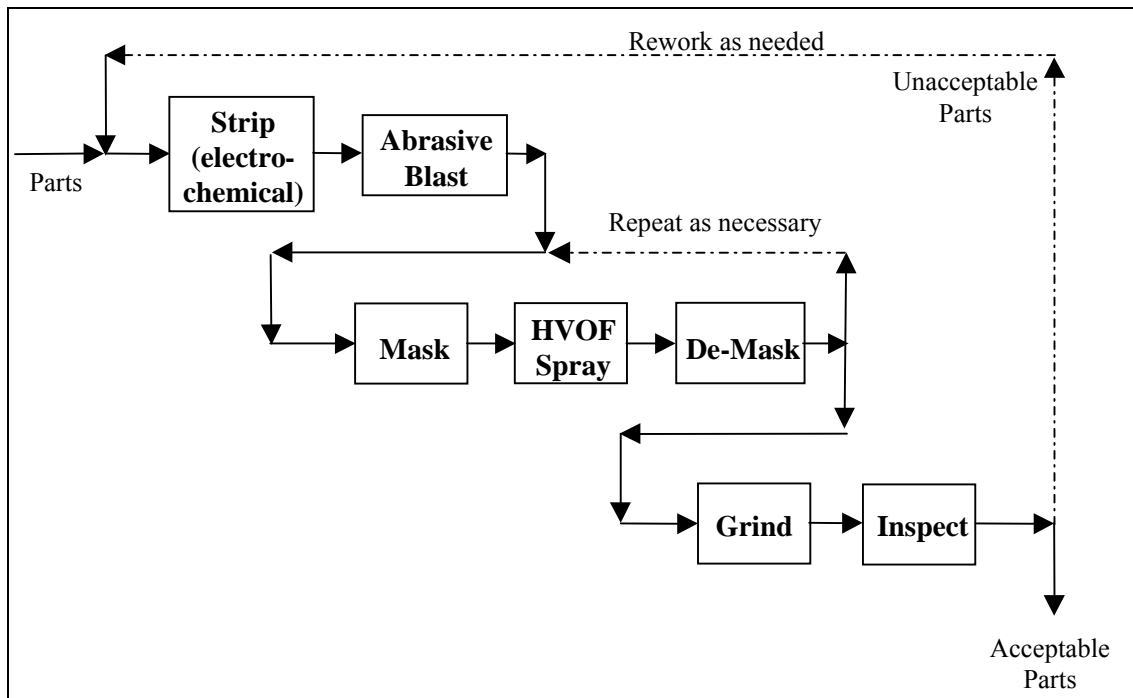

Figure 4-2. Process Flow of HVOF for Applying WC/Co

4.3. Data and Assumptions

Representatives from the repair/overhaul facility stated that approximately 270 aircraft propeller hubs are hard-chrome electroplated annually. This number includes rework of propeller hub components; the actual number of components coming into the facility and leaving the facility is smaller. This production workload can vary greatly from year to year, but this value was considered to be representative. Based on the reported number of propeller hubs hard-chrome electroplated annually, the average surface area of the processed propeller hubs, and the average use of chromic acid per unit surface area by other facilities, it was estimated that approximately 64 pounds (lb) of chromic acid is used each year for hard chrome electroplating of propeller hubs.

Three economic analyses were performed for this CBA. The first scenario, hereafter referred to as the Base Scenario, compares current hard chrome electroplating operations to a conservative scenario for implementing HVOF WC/Co. This Base Scenario includes only the most obvious and certain economic effects of replacing some hard chrome electroplating with HVOF WC/Co.

The second implementation scenario, hereafter referred to as Scenario 2, incorporates some additional, less conservative assumptions. These additional assumptions increase the estimated benefit (or decrease the estimated net cost) of implementing HVOF WC/Co. Also, these additional assumptions are judged to have a lower probability of matching reality than do the assumptions used for the Base Scenario. The third scenario (Scenario 3) also incorporates the effects of reduced turn-around time of aircraft propeller hub components.

Section 4.3.2 contains descriptions of assumptions that were made for the Base Scenario economic analysis. The assumptions associated with Scenario 2 are described in

Section 4.3.3, while Scenario 3 is described in Section 4.3.4.

4.3.1. Data Provided by Repair/Overhaul Facility

In addition to the average number of aircraft propeller hub components electroplated with hard chrome each year, the information listed below was collected from the facility

4.3.1.1. Current Hard Chrome Electroplating Operations

- A. Total labor requirements for all electroplating activities.
- B. The percentage of all electroplating activities that is hard-chrome electroplating.
- C. The percentage of total hard-chrome electroplating workload that is propeller hub components.
- D. Types of inputs (i.e., materials, energy, and labor) and outputs (e.g., air emissions, wastewater and hazardous waste) associated with stripping, abrasive blasting, masking, chrome plating, rinsing, de-masking, cleaning, baking, grinding and inspecting.
- E. An average rework rate for propeller hub components currently hard-chrome electroplated.
- F. Hazardous waste volume and treatment costs currently associated with hard-chrome electroplating and related electroplating activities.
- G. Wastewater volume sent to the internal wastewater treatment facility that is associated with hard-chrome electroplating and related electroplating activities and wastewater treatment costs.
- H. Types and quantities of PPE used for electroplating activities and cost per PPE item.
- I. Representative values (inventory values, in dollars) of propeller hubs hard-chrome electroplated.

The facility provided information and assumptions related to implementing HVOF WC/Co to replace hard chrome electroplating on all propeller hubs. These data and assumptions are described below.

4.3.1.2. Transitioning from Hard Chrome Electroplating to HVOF WCCo

- A. The major affected process steps include plating, baking and stripping.
- B. No upgrades of hard-chrome electroplating equipment are expected to be avoided in the next 15 years by implementing HVOF WC/Co.
- C. The facility has an existing, functional HVOF system capable of applying WC/Co to propeller hubs.
- D. The WC/Co coating will be applied to a 17-mil thickness.
- E. The surface area of an average propeller hub is approximately 1.5 square feet (ft²).

- F. All ovens currently used to bake hard chrome electroplated parts (to prevent hydrogen embrittlement) will continue to operate.
- G. No significant changes in operations in the electroplating area are expected as a result of implementing HVOF WC/Co for propeller hubs. For example, it is not expected that transitioning all hard-chrome electroplating of propeller hubs to HVOF application of WC/Co will result in elimination of any electroplating tanks or ventilation systems.
- H. Internal ESOH auditing costs are not expected to change.
- I. The facility is currently in compliance with all associated regulatory permits, and expects to remain in compliance, so no savings from avoiding fines are expected by transitioning to HVOF WC/Co.
- J. Hard-chrome electroplating processes are not expected to be moved to other locations because of compliance issues, so the project will not eliminate future relocation expenses.
- K. Masking and fixturing of propeller hubs for HVOF application of WC/Co is expected to be more costly than masking of propeller hubs for hard chrome electroplating (no cost estimate was provided).
- L. The HVOF processing time will be less than hard-chrome electroplating processing time, so the facility may realize some benefit from reduced turn-around time for the aircraft propeller hub components (Scenario 3).

4.3.2. Assumptions About Current and Future Operations – Base Scenario

The Base Scenario includes the potential effects of all direct (e.g., labor, material, and utility) and ESOH activity costs. The assumptions used to complete the economic analysis for the Base Scenario for this CBA are listed below.

- A. On average, propeller hubs are replated approximately every seven years.
- B. Current electroplating area labor rates are \$97 per hour (fully loaded).
- C. Material, utility and labor costs associated with hard chrome electroplating of propeller hubs include the following:
 - Chromic acid: 64 pounds (lb) per year (yr); \$145/yr
 - Sulfuric acid: 0.32 lb/yr; negligible cost
 - Deionized water: 10,300 gallons (gal)/yr; \$220/yr
 - Maskant: \$410/yr
 - Alkaline deruster: 0.49 gal/yr; \$12/yr
 - Sodium hydroxide: 15 lb/yr; \$2/yr

- Electricity: \$450 kilowatt-hours (kWh)/yr; \$36/yr
 - Natural gas for ovens (all electroplating): \$1,200/yr
 - Laboratory costs associated with process control: \$120/yr
 - Costs associated with ESOH-related activities other than waste disposal; \$44,120/yr.
- D. The labor rate for HVOF thermal spraying is the same as the labor rate for electroplating (\$97/hr fully loaded).
- E. WC/Co powder costs approximately \$29/lb, based on vendor quotes.
- F. An average propeller hub will require approximately 1.45 lb of WC/Co (17% Co), at a coating thickness of 17 mils. This assumption is based on the average density of WC/Co applied by HVOF and the average surface area of a propeller hub component.
- G. Material and utility costs associated with HVOF application of WC/Co are approximately \$2.25 per lb WC/Co powder sprayed for fuel, oxygen, nitrogen, cooling water, and compressed air.
- H. The HVOF spraying rate used for applying WC/Co will be 10 lb/hr.
- I. The rework rate for HVOF WC/Co coating is approximately 5%. This rework rate is based on engineering judgement.
- J. HVOF WC/Co deposit efficiency is approximately 50%.
- K. An average HVOF gun barrel costs approximately \$140, and must be replaced after spraying approximately 30 lb WCCo powder.
- L. The number of propeller hub components hard-chrome electroplated annually will remain constant for the entire 15-year study period unless HVOF WC/Co is implemented.
- M. The abrasive blasting, grinding and inspection steps will remain essentially unchanged when hard chrome electroplating of propeller hubs is replaced by HVOF WC/Co coating. Note that application of WC/Co will lead to a requirement for diamond grinding wheels. The diamond grinding wheels are expected to last longer than conventional grinding wheels, even when grinding WC/Co. The additional useful lifetime of the diamond grinding wheels is expected to offset the higher purchase cost of the diamond wheels.
- N. An HVOF system has a useful lifetime of at least 15 years.
- O. The additional cost of masking and fixturing propeller hubs for HVOF application of WCCo is approximately \$410/yr.
- P. OEMs will eliminate hard-chrome electroplating of propeller hubs shortly after implementation of the HVOF thermal spray process at the repair/overhaul facility. As a result, removal of hard-chrome electroplated coatings from propeller hubs will eventually cease

altogether.

- Q. The operation of the HVOF system to apply WC/Co to propeller hubs will be optimized before full implementation to increase efficiency.
- R. On average, one HVOF spray cell can process one propeller hub component with HVOF in approximately 40 minutes. Actual spraying of WC/Co powder is assumed to be approximately 50% of this time, while the rest of the total processing time is assumed to be used for setting up the part and spray pattern.
- S. The net cost for disposing of waste WC/Co is zero, because the material can be sold to a third party for reprocessing, with the proceeds offsetting any internal handling costs.
- T. Lifetime cartridge-type air filters will be used for filtering particulates from the HVOF WC/Co spray booth, so material costs will not be affected by filters.
- U. The cost of installing electrolytic stripping tanks for removing HVOF WC/Co coating was not included in capital costs. The annual material and utility costs for stripping WC/Co were assumed to be equivalent to baseline costs for stripping affected components that are hard-chrome electroplated.
- V. Implementation of HVOF WC/Co will not affect labor required for record keeping and reporting related to the use of HazMats.

4.3.3. Additional Assumptions for Scenario 2 [More Stringent OSHA Regulations on Chrome Exposure Enacted and Improved Durability/Performance of HVOF WC/Co Compared to Electroplated Hard Chrome]

To limit worker exposure to hazardous substances, OSHA has promulgated permissible exposure limits (PELs) which establish numerical standards to limit exposure in the workplace. The current PEL for chromic acid and chromates is specified at Table Z-2 in Title 29, Code of Federal Regulations, Part 1910.1000 (29 CFR §1910.1000). The current PEL for chromic acid and chromates is a ceiling limit of 100 micrograms per cubic meter of air ($100 \mu\text{g}/\text{m}^3$), measured as chromium trioxide (CrO_3). OSHA is currently working toward establishing a new, stricter standard for worker exposure to hexavalent chromium (chromium (VI)). OSHA is expected to issue a rule for general industry, agriculture and maritime work, with a separate standard for construction, although the date of this new rule is not known at this time. Reports indicate that OSHA is considering a new exposure limit in the range of $0.5 \mu\text{g}/\text{m}^3$ to $5 \mu\text{g}/\text{m}^3$ hexavalent chromium, and likely closer to $0.5 \mu\text{g}/\text{m}^3$.

Scenario 2 assumes that OSHA regulations regarding worker exposure to chrome are lowered to the range of $0.5 \mu\text{g}/\text{m}^3$ to $5 \mu\text{g}/\text{m}^3$. In addition, Scenario 2 incorporates the

effects of improved durability and performance of HVOF WC/Co compared to hard-chrome electroplated coatings. All assumptions used for the Base Scenario were also used for Scenario 2. The additional assumptions used for the Scenario 2 economic analysis for this CBA are listed below. The assumptions were developed based on input from the repair/overhaul facility or through engineering judgement and other analyses.

- A. If the hard-chrome electroplating workload remains at the current level, compliance with OSHA regulations in the electroplating area may be achieved by using chemical mist (fume) suppressants in the hard chrome electroplating tanks and limiting worker time in the hard - hrome electroplating area. Increased use of respirators is also expected, although compliance with OSHA regulations will not depend on the use of respirators.
- B. Chemical mist suppressants will cost approximately \$2,000 per 55-gallon drum, and approximately 2 gallons of mist suppressant will be required for each 1,000 gallons of make-up water for the hard-chrome electroplating tanks.
- C. Average worker time in the hard-chrome electroplating area must decrease by approximately 30% to meet OSHA regulations on chrome exposure. It is assumed that all personnel at each facility are currently fully utilized, so the decreased worker exposure must be achieved by hiring new personnel.
- D. Replacement frequency for respirator cartridges for each worker will be double the current practice in the hard-chrome electroplating area.
- E. Frequency of medical exams and health and safety training for each worker will be double the current levels.
- F. The more stringent OSHA rules on chrome exposure will go into effect in the year 2004, simultaneously with implementation of HVOF WC/Co.
- G. The useful lifetime of a propeller hub component coated with WC/Co by HVOF will be approximately 50% longer than the useful lifetime of hard-chrome electroplated propeller hub components. This increase in propeller hub lifetime is a conservative based on results of current ESTCP testing, published literature, and engineering judgment; some recent testing has shown wear resistance between 2.5 and 4 times as great as that of electroplated chrome. This increase in propeller hub lifetime will reduce the number of propeller hubs WC/Co-coated by HVOF by approximately 33%, starting in the seventh year after implementation of HVOF WCCo. The seventh year after HVOF WC/Co implementation is the first year in which propeller hubs coated with WC/Co by HVOF are expected to return to a depot for repair.
- H. Reducing the number of propeller hubs WC/Co-coated by HVOF will proportionally reduce material, labor and worker health and safety costs, but will not significantly affect waste disposal costs because hard chrome electroplating of propeller hubs is only approximately

10% of the hard-chrome electroplating workload at the facility.

The assumptions described above were made for the purposes of this economic analysis to estimate the effects of implementing HVOF WC/Co. The exact steps the facility would need to take to meet the projected more stringent OSHA rules cannot be determined at this time, and the purpose of this report is not to determine those steps. It is expected that more stringent OSHA rules on chrome exposure will also require the facility to invest in upgrades to hygiene facilities and ventilation. These expected upgrades were not included in this analysis, because propeller hubs are a small portion of the current hard-chrome electroplating workload.

In addition, the effects of increasing the useful lifetime of propeller hubs will not be observable until approximately the seventh year after implementation of HVOF WC/Co. It should be noted that the analysis does not include any effects on aircraft operating costs caused by the difference between the density of HVOF WC/Co and the density of electroplated hard chrome.

4.3.4. Additional Assumptions for Scenario 3 (Scenario 2 plus Benefits from Decreased Turn-Around Time)

The third scenario used for an economic analysis of the effects of replacing some hard-chrome electroplating with HVOF WC/Co assumes benefits from decreased turn-around time (TAT) of propeller hubs. Because the facility has reported no difficulty in meeting required schedules for processing aircraft propeller hub components, the cost avoidance associated with decreased TAT in Scenario 3 is not expected to accrue directly to the facility after implementing HVOF WC/Co. All assumptions used for Scenario 2 were also used for Scenario 3. The additional assumptions used for the Scenario 3 economic analysis are listed below.

- A. The average TAT for propeller hubs coated with WC/Co by HVOF will be approximately 5 days less than the average TAT for hard chrome electroplated propeller hub components.
- B. The average value of a propeller hub is \$60,000.
- C. The annual interest rate used to calculate the “inventory cost” for propeller hubs is 2.7%; this is consistent with the 10-year real interest rate listed in Office of Management and Budget (OMB) Circular Number A-94 (January 1999 revision) [4.4].

4.4. Annual Operating Cost Avoidance

Data and assumptions described in Section 4.3 were used to calculate the current annual operating costs for coating aircraft propeller hub components using the baseline hard chrome electroplating process. These data and assumptions were also used to estimate the annual operating costs for servicing aircraft propeller hub components with HVOF WC/Co. The annual operating cost avoidances reported in this section were derived from

comparing the operating costs of the baseline hard-chrome electroplating process to those calculated for the three scenarios described in Section 4.3.2, Section 4.3.3 and Section 4.3.4.

Table 4-1 shows the annual operating cost avoidances that were estimated for implementing HVOF WC/Co coating to replace hard chrome electroplating of propeller hubs at the repair/overhaul facility. Scenario 2 includes an assumption that the average number of propeller hubs that need to be repaired and maintained will decrease beginning in the seventh year after implementation because of superior performance and durability of WC/Co coatings applied by HVOF. Scenario 3 includes a benefit from reduced TAT, which is not expected to accrue directly to the facility.

Table 4-1 . Estimated Annual Operating Cost Avoidance

Category	Base Scenario	Scenario 2	
		Years 1-6	Years 7-15
Parts/Year Hard-Chrome Electroplated Without HVOF Implementation	270	270	270
Parts/Year Coated with HVOF WC/Co After HVOF Implementation	250	250	170
Annual Operating Cost Avoidance			
Labor	\$0	\$0	\$0
Materials and Utilities	(\$26,000)	(\$26,000)	(\$17,000)
ESOH Activities			
Waste Disposal	\$340	\$340	\$340
Other ESOH Activities	\$0	\$510	\$400
Total	(\$26,000)	(\$25,000)	(\$16,000)
Additional Cost Avoidance due to Reduced TAT (Scenario 3)	N.A.	\$5,600	\$3,700
Total Scenario 3	N.A.	(\$19,000)	(\$12,000)

Values in “()” indicate negative values, or loss. All values are rounded to two significant digits.

N.A. = Not applicable

In all scenarios investigated, cost avoidances are expected in ESOH activities, but the total annual operating costs are expected to increase after implementing HVOF WC/Co.

4.5. Summary and Recommendations

HVOF application of WC/Co is being investigated as an alternative to hard-chrome electroplating for overhauling aircraft propeller hubs. HVOF application of WC/Co may be technically feasible for use at OEMs as well as DoD maintenance facilities.

A CBA was performed to identify the potential financial impact of implementing HVOF WCCo at a repair/overhaul facility for application to aircraft propeller hub components. Data were collected at this facility and the potential economic effects were calculated in accordance with the JG-PP CBA methodology.

It was estimated that the use of HVOF WC/Co for propeller hubs will result in a net increase in annual operating costs. The additional annual operating costs range from \$12,000 to \$26,000, based on a number of differing assumptions described in this CBA. This analysis assumes that HVOF WC/Co will be implemented only for use on propeller hubs. Because propeller hubs are only a small portion of the hard-chrome electroplating workload at the facility, this analysis does not consider possible avoidance of costs associated with potential future changes to OSHA chrome exposure limits. The limited implementation considered in this analysis also does not represent the most efficient use of the HVOF thermal spray equipment at the facility. Finally, this analysis assumes that HVOF WC/Co will exhibit a 50% extension of service life over the service life of electroplated chrome. WC/Co applied by HVOF has reportedly shown wear resistance up to four times as great as that of electroplated chrome in the materials testing described earlier in this report. Therefore, greater benefits to the facility and to DOD weapon system programs may be realized through implementation of HVOF WC/Co due to increased service life of propeller hubs.

This cost analysis was done in 1999. A more recent CBA performed at a landing gear overhaul facility [4.5] showed that the 15-year net present value of implementing HVOF in place of hard chrome plating was approximately \$2,000,000. This raises the issue of why a positive return-on-investment would be obtained at the landing gear facility whereas a negative one was obtained for the propeller hub facility. The major difference is that at the landing gear facility, HVOF would be able to replace approximately 75% of the chrome plating workload and the number of components processed annually would be considerably higher than at the propeller hub facility where overhaul of those types of components only represents 10% of the chrome plating workload. The replacement of a large fraction of the chrome plating operations results in substantial savings in areas such as waste disposal, plating tank maintenance and worker safety monitoring. Replacing only a small fraction of the chrome plating workload does not lead to equivalent savings and is very inefficient. It can be concluded that any CBA performed at a repair facility that applies hard chrome plating to many different types of components should take into account all of those that could be replaced with HVOF and not just a small segment in order to achieve the most accurate picture of potential cost savings.

It can be concluded that the economic feasibility of HVOF implementation is highly dependent on site-specific details. Any facility considering implementation of HVOF WC/Co to replace hard-chrome electroplating should perform an economic analysis specific to the facility. Based on this analysis, it is recommended that all propeller hub repair/overhaul facilities carefully review those factors driving them to consider replacing

hard-chrome electroplating with HVOF WC/Co. If other factors that are expected to make HVOF WC/Co financially feasible are revealed or confirmed, another economic analysis should be performed incorporating those new factors. Such factors may include additional applications suitable for HVOF WC/Co at the facility (for economies of scale) or operational validation of greatly enhanced wear characteristics of WC/Co.

The actual economic effects at any facility will vary depending on the number of actual applications converted, future workloads, and other factors specific to each facility.

4.6. References

- 4.1 “Cost Benefit Analysis (HV-C-1-1) for High-Velocity Oxygen-Fuel Deposition of WC/Co as an Alternative to Hard Chrome Electroplating for Aircraft Landing Gear Components.” Engineering and Technical Services for Joint Group on Acquisition Pollution Prevention (JG-APP) Pilot Projects. Contract No. DAAA21-93-C-0046. Task No. N.072. CDRL No. A010. Concurrent Technologies Corporation, Johnstown, PA. Draft July 14, 1998.
- 4.2 “Environmental Cost Analysis Methodology (ECAM) Handbook.” Environmental Security Technology Certification Program (ESTCP) Validation Tasks. Contract No. DAAA21-93-C-0046. Task No. 098. CDRL No. A013. Concurrent Technologies Corporation, Johnstown, PA. March 29, 1999.
- 4.3 “Environmental Cost Analysis Methodology Implementation Report. Appendix 4 of 5: Naval Aviation Depot at Jacksonville, Florida (NADEP-JAX).” Environmental Security Technology Certification Program (ESTCP) Validation Tasks. Contract No. DAAA21-93-C-0046. Task No. 098. CDRL No. A012. Concurrent Technologies Corporation, Johnstown, PA. January 7, 1998.
- 4.4 “OMB Circular No. A-94 (Revised), Guidelines and Discount Rates for Benefit-Cost Analysis of Federal Programs.” Washington, DC. October 29, 1992. Revised January 1999.
- 4.5 “Final Cost Benefit Analysis S-98-MF-011-C for Validation of WC/Co and WC/CoCr HVOF Thermal Spray Coatings as a Replacement for Hard Chrome Plating on Aircraft Landing Gear.” Prepared by National Defense Center for Environmental Excellence for the Joint Group on Pollution Prevention, September 2002.

4.7. Other Sources of Information

- Facsimile communication. Larry Stiles. Hobart-Tafa Technologies. Concord, NH. May 28, 1998.
- *JP-5000 Comparative Operating Costs*. Technical Data. Hobart-Tafa Technologies. Concord, NH. 1992.

- *Ordering Information.* ACM Products Company. World Wide Web site at <http://www.acmproducts.com/orderinfo.htm#abrasive>. Accessed September 23, 1999. Last modified September 1, 1998.
- *PCD Tooling Justification Report.* Alpex Wheel Company. World Wide Web site at <http://www.alpexwheel.com/PCD/pcdjust.html>. Accessed September 23, 1999. Last modified May 28, 1998.
- *Spray Parameters.* Technical Data. Hobart-Tafa Technologies. Concord, NH. 1997.
- Telephone conversation. Ken Beatty. Sulzer Metco. Westbury, NY. June 2, 1998.
- Telephone conversation. Tom Murphy. Hobart-Tafa Technologies. Concord, NH. March 24, 1998.
- 29 CFR §1910.100

5. Summary and Implementation of HVOF Technology

5.1. Performance of HVOF vs. EHC Coatings

The materials testing showed that in fatigue and wear testing the HVOF WC/Co coatings were significantly better than hard chrome, and would be a suitable replacement for EHC in the repair of the low-pitch-stop lever sleeve and hub tail shaft for 54H60 and 54460 propellers.

In corrosion testing, which was compared with the Ni plate currently used for repair of rocking lands on 54460 propeller hubs, Ni performed best, followed by WC/CoCr, Tribaloy-800, then WC/Co. Nevertheless, WC/CoCr corrosion performance was considered adequate to use it as a replacement for Ni plating as well as EHC plating, further reducing the environmental impact of propeller hub overhaul. Since WC/CoCr showed significantly better wear performance, both in reduced component wear and reduced seal material wear, it was expected to provide a significant benefit in reduced depot and field maintenance.

Because of the issues associated with coating spallation at high stresses and strains that arose in the landing gear project, Hamilton-Sundstrand recommended additional compression-compression fatigue testing to ensure that this is not a problem for propeller hubs. (It is not expected to be a problem since these components are not subject to high bending stresses.) This additional testing is ongoing.

The HVOF coatings that were evaluated in the materials testing were sprayed with unusually high compressive stress. Hamilton Sundstrand recommended that some comparisons be made with performance of coatings deposited by other vendors. Presumably NADEP-CP would also spray with a lower compressive stress. The primary effect of this is on fatigue, where high compressive stress improves fatigue life. However, excessive compressive stress carries with it the danger of inducing too high a tensile stress in the substrate, with a potential for enhanced crack propagation in the substrate and reduced fatigue. Therefore, since fatigue was not an issue, HVOF coatings should still have better fatigue performance than EHC even with a lower residual stress in the HVOF coating.

The performance of the rig tests on the low-pitch-stop lever sleeve confirmed the observations of the coupon tests. The HVOF coated components, as well as their matching components, showed no wear or very slight wear, whereas chrome showed low but noticeable wear. Therefore, it is anticipated that, in common with other components, the overhaul frequency could probably be reduced, with a cycle time from 1.5 – 4 times longer.

5.2. Cost of HVOF vs. EHC Coatings

The facility for which the CBA was performed overhauls many other types of aircraft components and the repairs done on propeller hub components represent less than 20% of the total chrome plating workload. For comparison purposes, the facility for which the

landing gear CBA was performed overhauls primarily landing gear and thus HVOF would replace more than 85% of the chrome plating workload. The 15-year net-present-value at that facility for implementation of HVOF was close to \$2,000,000 [5.1]. Thus, it is quite possible that if the facility that repairs the propeller hub components is able to replace most of its entire chrome plating workload with HVOF, it could see similar cost savings. Furthermore, incorporating the cost savings from avoidance of scrapping components is likely to change the NPV calculations significantly.

A major contributor to HVOF process cost is the cost of spray powder. Spray efficiency is an important contributor to this cost since any powder that does not stick (i.e. becomes overspray) is lost and goes into the filter system. Therefore optimizing the process for spray efficiency would have a major impact on long term cost. This is likely to be a cost-effective process improvement.

In the long term it is also possible to use a different, less expensive powder. However, in this case, since the longevity of the coating is critical to this weapons system, this would only lead to a net saving if the performance of the new coating is essentially the same as that of WC/Co. It would also lead to additional qualification costs.

5.3. Standards and Specifications

One of the key end user/OEM issues is the availability of standards and specifications related to the powder used for HVOF coatings, application procedures for the coatings, and grinding procedures for the coatings. Although standards and specifications were not developed specifically for the propeller hub project, in the landing gear project the HCAT worked with the SAE Aerospace Metals Engineering Committee to develop four separate specifications in these areas [5.2]. Those related to powder and coating deposition were completed and forwarded to SAE Aerospace Materials Committee B, who approved them in February 2003. The following are the designations:

- ◆ AMS 2448 – “Application of Tungsten Carbide Coatings on Ultra-High-Strength Steels, High-Velocity Oxygen/Fuel Process”
- ◆ AMS 7881 – “Tungsten Carbide-Cobalt Powder, Agglomerated and Sintered”
- ◆ AMS 7882 – “Tungsten Carbide-Cobalt Chromium Powder, Agglomerated and Sintered”

In addition, United Technologies Hamilton Sundstrand has developed HS 4412 for application of HVOF thermal spray coatings in place of EHC.

A specification for grinding and superfinishing of the coatings has been drafted and is in the approval process. All of these specifications can now be utilized by any manufacturing or overhaul depot and their use will result in consistency between facilities with respect to coating properties.

5.4. Implementation of HVOF Thermal Spray Coatings in Manufacturing and Repair/Overhaul Operations

It is instructive to note that the materials testing under this project led not only to an EHC replacement, but to an alternative to Ni plating repair. Although Ni is not yet as high on the list of environmentally unacceptable materials as Cr, it is a “toxic 17” material that is coming under increasing regulation. The “toxic 17” chemicals were defined in the EPA 33/50 program. These are 17 chemicals considered particularly widespread and toxic (including Cr, Ni, Cd, mercury and cyanides) that participating companies voluntarily pledged to reduce to 33% of their 1988 levels by 1992 and 50% by 1995. Although the 33/50 program is no longer in effect, toxic material elimination efforts still target the remaining uses of these materials.

The usage of HVOF in this instance, using a different coating material than that used for EHC, shows the power of the HVOF technology. Not only can HVOF replace Cr, but it can also replace other materials. Furthermore, both materials can be sprayed on the same part in a single spray run simply by automatically switching powder feeders, without the need for recleaning, remasking, rebaking for embrittlement relief, and all the other requirements of two separate electroplating processes. This suggests that, when replacing one process with another, especially with one as general as HVOF, additional process modifications should be explored that will eliminate other environmentally unsound processes while reducing the total overhaul cost.

The HVOF systems currently in operation at aerospace-qualified HVOF vendors and at the NADEPs and ALCs are full-production systems with fixturing for manipulation of various types of components and robots on which the HVOF spray guns are mounted. The original spray booth at NADEP CP that was acquired using ESTCP funds has now been supplemented by an additional, similar booth acquired by the NADEP to meet demand. These two booths are expected to be used for processing propeller hub components, landing gear, and other items for fixed-wing and rotary-wing aircraft.

WR-ALC, which is responsible for a high volume of C-130 propeller system overhauls, now has a production-capable HVOF system and it is anticipated that it will be used for processing C-130 propeller components.

Hamilton Sundstrand purchases its HVOF services from various commercial vendors, such as Engelhard’s local spray shop in Windsor Locks, CT. These commercial shops already use full scale HVOF equipment.

For final qualification of the HVOF coatings on propeller hub components, a P-3 engine test is currently in progress at Hamilton Sundstrand and a flight test of a P-3 containing HVOF WC/Co coatings on propeller hub components is to begin in the summer of 2003. NAVAIR has stated that a 6-month trouble-free flight test will suffice for qualification. This same technology will then be implemented at WR-ALC, where a larger number of C-130 propeller hubs are overhauled.

The primary factor likely to slow implementation at the depot is obtaining final NAVAIR approval for a change in repair specifications. Unlike Ogden ALC, which is the

cognizant authority able to authorize repair changes for landing gear, NADEP-CP must obtain NAVAIR authorization for the repair. However, since the program was done in very close collaboration with the OEM, Hamilton Sundstrand, and much of the testing was done by the manufacturer, there should be no issue with the manufacturer endorsing the change. Indeed, as pointed out above, NAVAIR has agreed to a limited flight test for final qualification. Since Hamilton Sundstrand intends to adopt the technology on new components, any new purchases will already incorporate HVOF coatings, with HVOF being the OEM-specified repair as well.

5.5. References

- 5.1 “Final Cost Benefit Analysis S-98-MF-011-C for Validation of WC/Co and WC/CoCr HVOF Thermal Spray Coatings as a Replacement for Hard Chrome Plating on Aircraft Landing Gear.” Prepared by National Defense Center for Environmental Excellence for the Joint Group on Pollution Prevention, September 2002.
- 5.2 ESTCP Final Report, “Replacement of Chromium Electroplating on Landing Gear Components Using HVOF Thermal Spray Coatings.” Naval Research Laboratory, Washington, DC, October 2003.