

LISTA PROVA 2

Shapiro, 4ª edição.

4.4 Data are provided for the crude oil storage tank shown in Fig. The tank initially contains 1000 m^3 of crude oil. Oil is pumped into the tank through a pipe at a rate of $2 \text{ m}^3/\text{min}$ and out of the tank at a velocity of 1.5 m/s through another pipe having a diameter of 0.15 m . The crude oil has a specific volume of $0.0015 \text{ m}^3/\text{kg}$. Determine (a) the mass of oil in the tank, in kg, after 24 hours, and (b) the volume of oil in the tank, in m^3 , at that time.

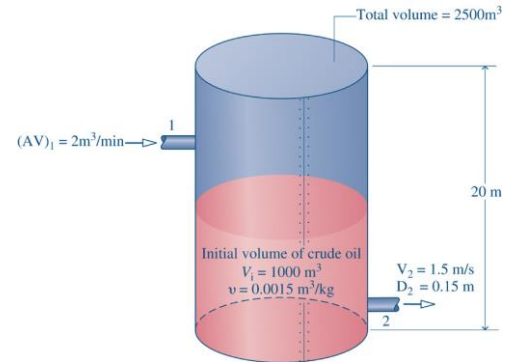

4.9 Air enters a one-inlet, one-exit control volume at 6 bar, 500 K, and 30 m/s through a flow area of 28 cm^2 . At the exit, the pressure is 3 bar, the temperature is 456.5 K, and the velocity is 300 m/s. The air behaves as an ideal gas. For steady-state operation, determine (a) the mass flow rate, in kg/s. (b) the exit flow area, in cm^2 .

4.22 Figure shows a cylindrical tank being drained through a duct whose cross-sectional area is $3 \cdot 10^{-4} \text{ m}^2$. The velocity of the water at the exit varies according to $(2gz)^{1/2}$, where z is the water level, in m, and g is the acceleration of gravity, 9.81 m/s^2 . The tank initially contains 2500 kg of liquid water. Taking the density of the water as 10^3 kg/m^3 , determine the time, in minutes, when the tank contains 900 kg of water.

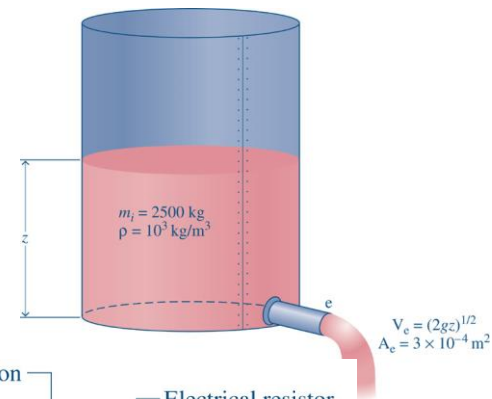

4.25 As shown in Fig., air enters a pipe at 25°C , 100 kPa with a volumetric flow rate of $23 \text{ m}^3/\text{h}$. On the outer pipe surface is an electrical resistor covered with insulation. With a voltage of 120 V, the resistor draws a current of 4 A. Assuming the ideal gas model with $c_p = 1,005 \text{ kJ/kg} \cdot \text{K}$ for air and ignoring kinetic and potential energy effects, determine (a) the mass flow rate of the air, in kg/h, and (b) the temperature of the air at the exit, in $^\circ\text{C}$.

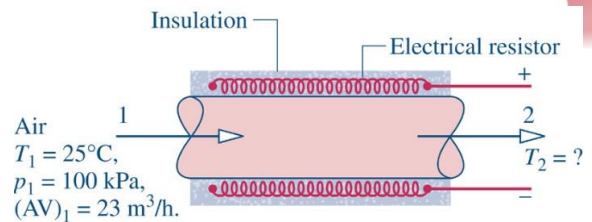

4.43 Air expands through a turbine from 8 bar, 960 K to 1 bar, 450 K. The inlet velocity is small compared to the exit velocity of 90 m/s. The turbine operates at steady state and develops a power output of 2500 kW. Heat transfer between the turbine and its surroundings and potential energy effects are negligible. Modeling air as an ideal gas, calculate the mass flow rate of air, in kg/s, and the exit area, in m^2 .

4.50 Steam enters the first-stage turbine shown in Fig. at 40 bar and 500°C with a volumetric flow rate of $90 \text{ m}^3/\text{min}$. Steam exits the turbine at 20 bar and 400°C . The steam is then reheated at constant pressure to 500°C before entering the second-stage turbine. Steam leaves the second stage as saturated vapor at 0.6 bar. For operation at steady state, and ignoring stray heat transfer and kinetic and potential energy effects, determine the (a) mass flow rate of the steam, in kg/h. (b) total power produced by the two stages of the turbine, in kW. (c) rate of heat transfer to the steam flowing through the reheater, in kW.

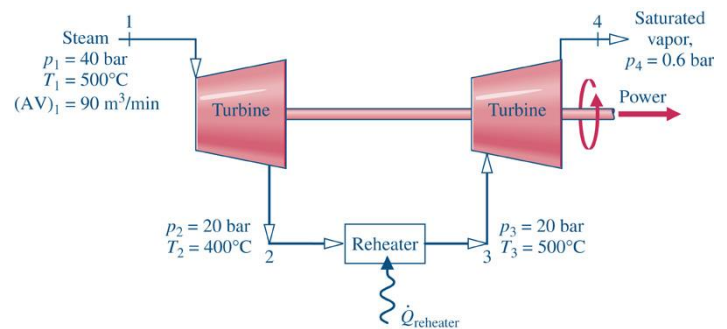

4.77 Refrigerant 134a enters a heat exchanger at 212°C and a quality of 42% and exits as saturated vapor at the same temperature with a volumetric flow rate of $0.85 \text{ m}^3/\text{min}$. A separate stream of air enters at 22°C with a mass flow rate of 188 kg/min and exits at 17°C . Assuming the ideal gas model for air and ignoring kinetic and potential energy effects, determine (a) the mass flow rate of the Refrigerant 134a, in kg/min, and (b) the heat transfer between the heat exchanger and its surroundings, in kJ/min.

4.80 A feedwater heater in a vapor power plant operates at steady state with liquid entering at **inlet 1** with $T_1 = 45^\circ\text{C}$ and $p_1 = 3.0$ bar. Water vapor at $T_2 = 320^\circ\text{C}$ and $p_2 = 3.0$ bar enters at **inlet 2**. Saturated liquid water exits with a pressure of $p_3 = 3.0$ bar. Ignore heat transfer with the surroundings and all kinetic and potential energy effects. If the mass flow rate of the liquid entering at **inlet 1** is $\dot{m}_1 = 3,2 \cdot 10^5 \text{ kg/h}$, determine the mass flow rate at **inlet 2**, \dot{m}_2 , in kg/h.

4.100 Carbon dioxide (CO_2) modeled as an ideal gas flows through the compressor and heat exchanger shown in Fig. The power input to the compressor is 100 kW. A separate liquid cooling water stream flows through the heat exchanger. All data are for operation at steady state. Stray heat transfer with the surroundings can be neglected, as can all kinetic and potential energy changes. Determine (a) the mass flow rate of the CO_2 , in kg/s, and (b) the mass flow rate of the cooling water, in kg/s.

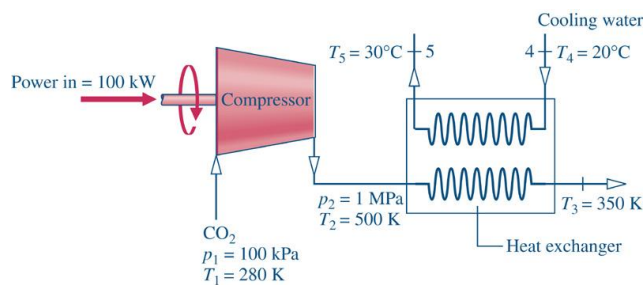

4.124 The rigid tank illustrated in Fig. has a volume of 0.06 m^3 and initially contains a two-phase liquid–vapor mixture of H_2O at a pressure of 15 bar and a quality of 20%. As the tank contents are heated, a pressure-regulating valve keeps the pressure constant in the tank by allowing saturated vapour to escape. Neglecting kinetic and potential energy effects (a) determine the total mass in the tank, in kg, and the amount of heat transfer, in kJ, if heating continues until the final quality is $x = 0.5$. (b) plot the total mass in the tank, in kg, and the amount of heat transfer, in kJ, versus the final quality x ranging from 0.2 to 1.0.

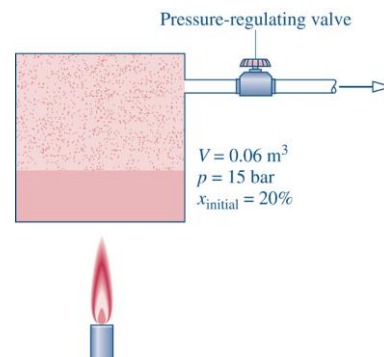

5.17 The data listed below are claimed for a power cycle operating between hot and cold reservoirs at 1000 K and 300 K, respectively. For each case, determine whether the cycle *operates reversibly*, *operates irreversibly*, or *is impossible*.

- (a) $Q_H = 600 \text{ kJ}$, $W_{\text{cycle}} = 300 \text{ kJ}$, $Q_C = 300 \text{ kJ}$; (b) $Q_H = 400 \text{ kJ}$, $W_{\text{cycle}} = 280 \text{ kJ}$, $Q_C = 120 \text{ kJ}$
 (c) $Q_H = 700 \text{ kJ}$, $W_{\text{cycle}} = 300 \text{ kJ}$, $Q_C = 500 \text{ kJ}$; (d) $Q_H = 800 \text{ kJ}$, $W_{\text{cycle}} = 600 \text{ kJ}$, $Q_C = 200 \text{ kJ}$

5.36 At steady state, a power cycle develops a power output of 10 kW while receiving energy by heat transfer at the rate of 10 kJ per cycle of operation from a source at temperature T . The cycle rejects energy by heat transfer to cooling water at a lower temperature of 300 K. If there are 100 cycles per minute, what is the minimum theoretical value for T , in K?

5.40 At steady state, a 750MW power plant receives energy by heat transfer from the combustion of fuel at an average temperature of 317°C . As shown in Fig., the plant discharges energy by heat transfer to a river whose mass flow rate is $1.65 \times 10^5 \text{ kg/s}$. Upstream of the power plant the river is at 17°C . Determine the increase in the temperature of the river, ΔT , traceable to such heat transfer, in $^\circ\text{C}$, if the thermal efficiency of the power plant is (a) the Carnot efficiency of a power cycle operating between hot and cold reservoirs at 317°C and 17°C , respectively, (b) two-thirds of the Carnot efficiency found in part (a). Comment.

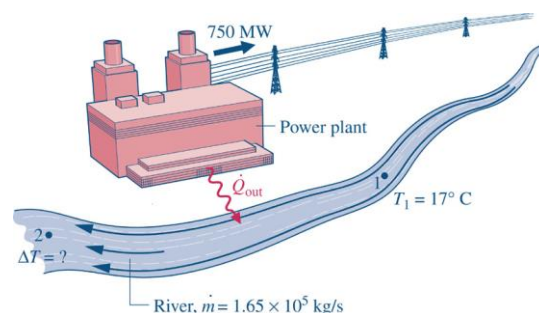

5.55 By removing energy by heat transfer from its freezer compartment at a rate of 1.25 kW, a refrigerator maintains the freezer at -26°C on a day when the temperature of the surroundings is 22°C . Determine the minimum theoretical power, in kW, required by the refrigerator at steady state.

5.63 A refrigeration cycle has a coefficient of performance equal to 75% of the value for a reversible refrigeration cycle operating between cold and hot reservoirs at -5°C and 40°C , respectively. For operation at steady state, determine the net power input, in kW per kW of cooling, required by (a) the actual refrigeration cycle and (b) the reversible refrigeration cycle. Compare values.

5.79 Two kilograms of air within a piston–cylinder assembly execute a Carnot power cycle with maximum and minimum temperatures of 750 K and 300 K, respectively. The heat transfer to the air during the isothermal expansion is 60 kJ. At the end of the isothermal expansion, the pressure is 600 kPa and the volume is 0.4 m^3 . Assuming the ideal gas model for the air, determine (a) the thermal efficiency.; (b) the pressure and volume at the beginning of the isothermal expansion, in kPa and m^3 , respectively.; (c) the work and heat transfer for each of the four processes, in kJ. ;(d) Sketch the cycle on p – V coordinates.

5.86 Figure gives the schematic of a vapor power plant in which water steadily circulates through the four components shown. The water flows through the boiler and condenser at constant pressure and through the turbine and pump adiabatically. Kinetic and potential energy effects can be ignored. Process data follow:

Process 4–1: constant-pressure at 1 MPa from saturated liquid to saturated vapor

Process 2–3: constant-pressure at 20 kPa from $x_2 = 88\%$ to $x_3 = 18\%$

(a) Using Eq. 5.13 expressed on a time-rate basis, determine if the cycle is internally reversible, irreversible, or impossible.

(b) Determine the thermal efficiency using Eq. 5.4 expressed on a time-rate basis and steam table data.

(c) Compare the result of part (b) with the Carnot efficiency calculated using Eq. 5.9 with the boiler and condenser temperatures and comment.

