

Fig. 5.8b.

Fig. 5.8a, b. Pressing of parts with two holes

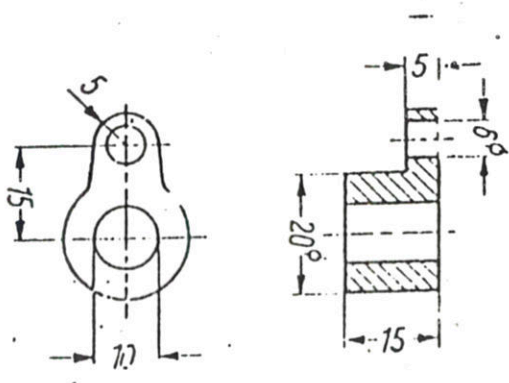

Fig. 5.8a.

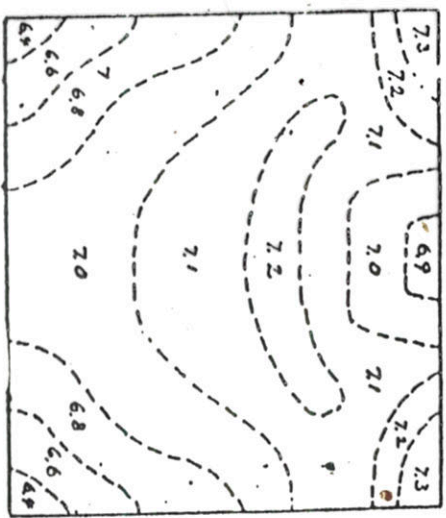

Fig. 5.9. Distribution of densities in "green" nickel compact. Unidirectionally (single action) compacted at 103,000 psi. (Diam: 0.79 inch; height: 0.69 inch)

(Acc. to Kuczny)

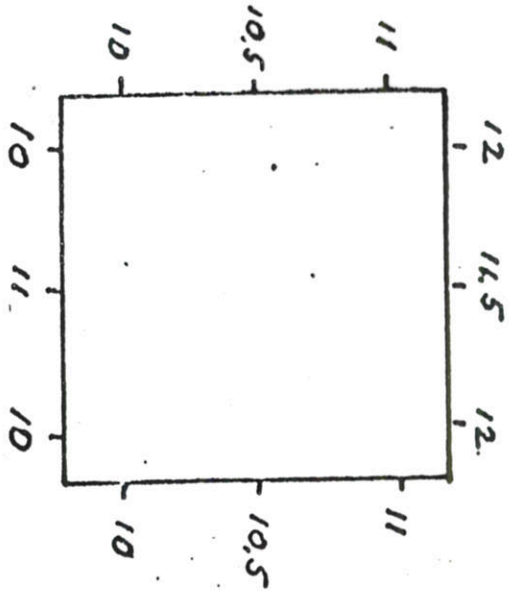

Fig. 5.10. Distribution of Shore hardness in compacts pressed in single action