



Me. Tecgo. Oswaldo B. Loureda

Filosofia da Empresa

- Desenvolver tecnologia de ponta focada para o desenvolvimento de Veículos Lançadores e de Sondagem.
- Aplicar estas tecnologias em consultoria a indústria nacional, buscando otimização através da pesquisa.
- Trazer os resultados para as instituições de ensino através de projetos didático-científicos.

Equipe Efetiva da Acrux LTDA ME

- Me. Engenharia Aeroespacial
- Tecgo. Manufatura Aeronáutica
- Téc. Desenvolvimento de Produtos
- Téc. Mecânica
- 2 Jovens Aprendizes

Consultores

- Prof. Dr. Amilcar P. Pimenta (ITA)
- Prof. Dr. Geraldo Adabo (ITA)
- Prof. Dr. José Atilio Fritz (ITA)
- Prof. Dr. Luiz Pardini (ITA/IAE)
- Prof. Dr. Marcelo Souza (UENF)
- Prof. Dr. João B. Garcia Canalle (UERJ)
- Prof. Dr. Geilson Loureiro (INPE)



Acrux Aerospace Technologies

- Foguetes de Sondagem de Pequeno Porte (Educativo e Científico)

FOG1K
FOG5K
FOG10K
FOG30K





Acrux Aerospace Technologies

- Projeto e Desenvolvimento de Componentes para MFPL

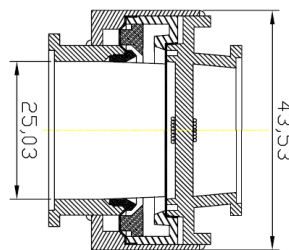
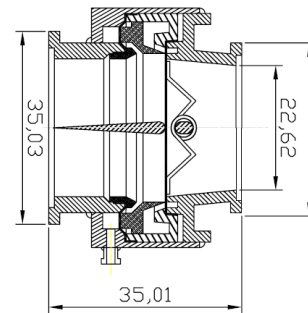
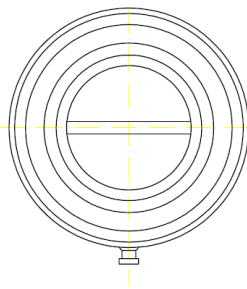
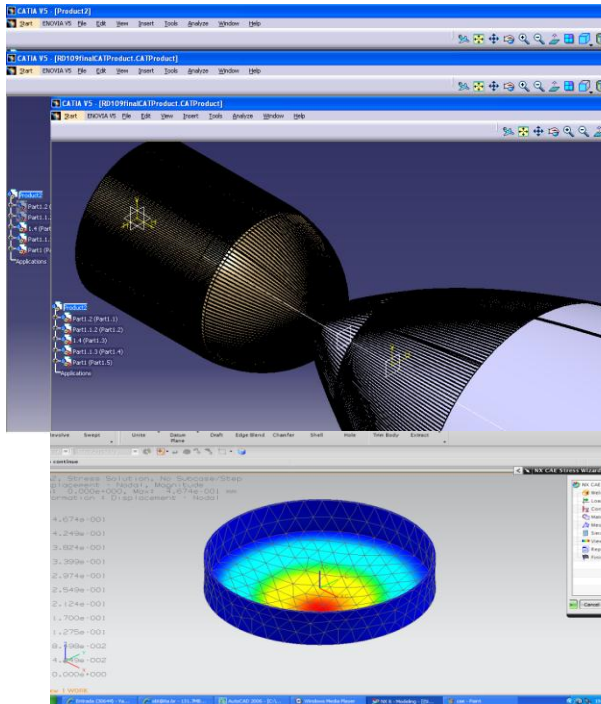

Fabricação do Mock-Up LRE L75 (IAE)

- NanoLançador MONTENEGRO-VX₀₃ - Viabilidade Comercial

10kg em LEO 300km 0°

Custo Objetivo US\$ 0,5M

5 Pods p/ CubeSats até 3U

4 Pods p/ CubeSats até 1U

12 Pods p/ CanSats

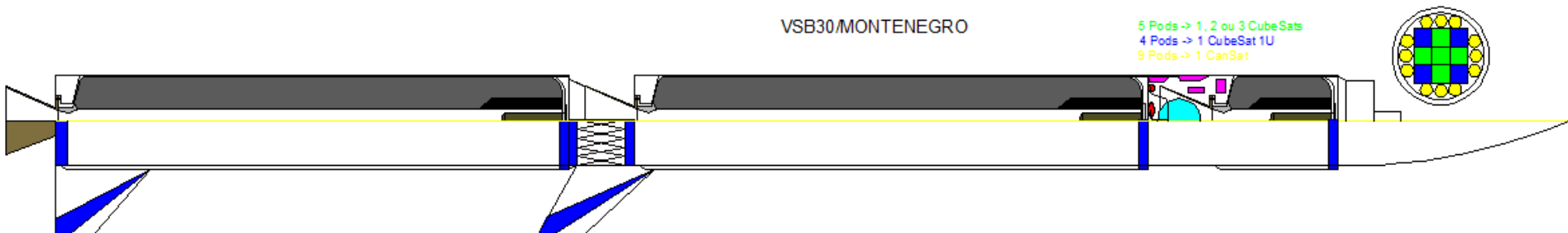

2100kg (HTPB/Al/AP)



Acrux Aerospace Technologies

- Projeto e Desenvolvimento de Componentes para VANTs

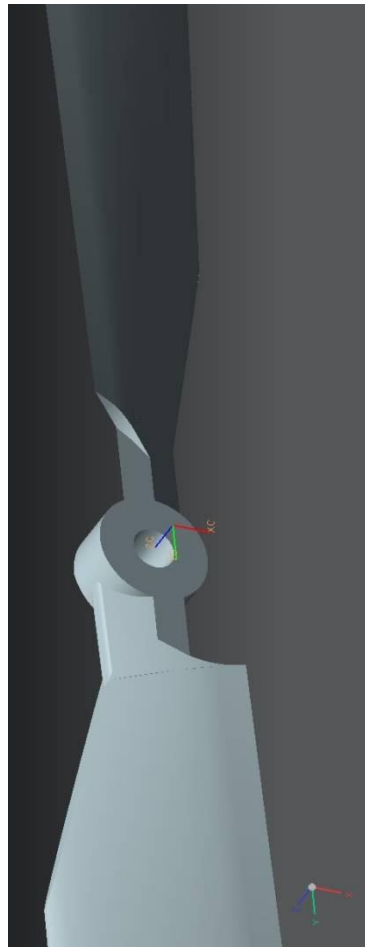
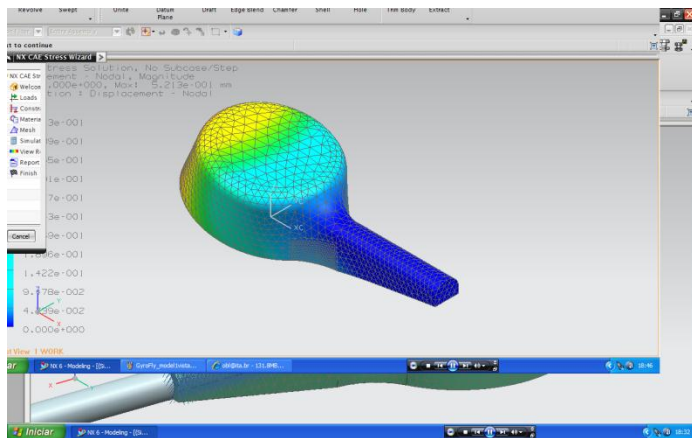
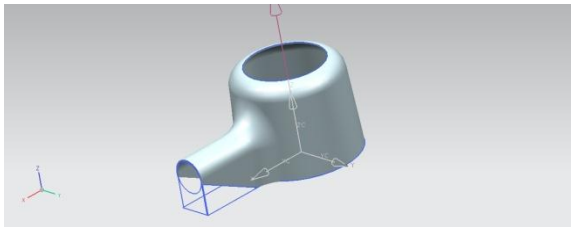
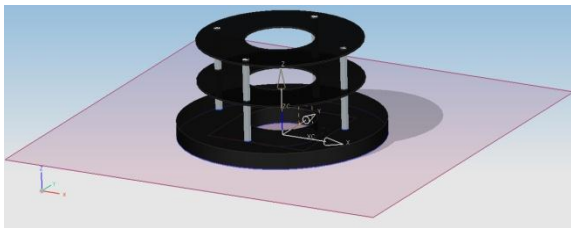



Acrux Aerospace Technologies



AGRO - UAV

Wing Span: 2550 mm
Length: 1075 mm
Payload: 2kg
Take-off Mass: 5kg
Hand-Launched
Flight Duration: 2 hs
Engine Power: 300 W (Brushless)
All Composite Airframe
Solar Power: 8 W

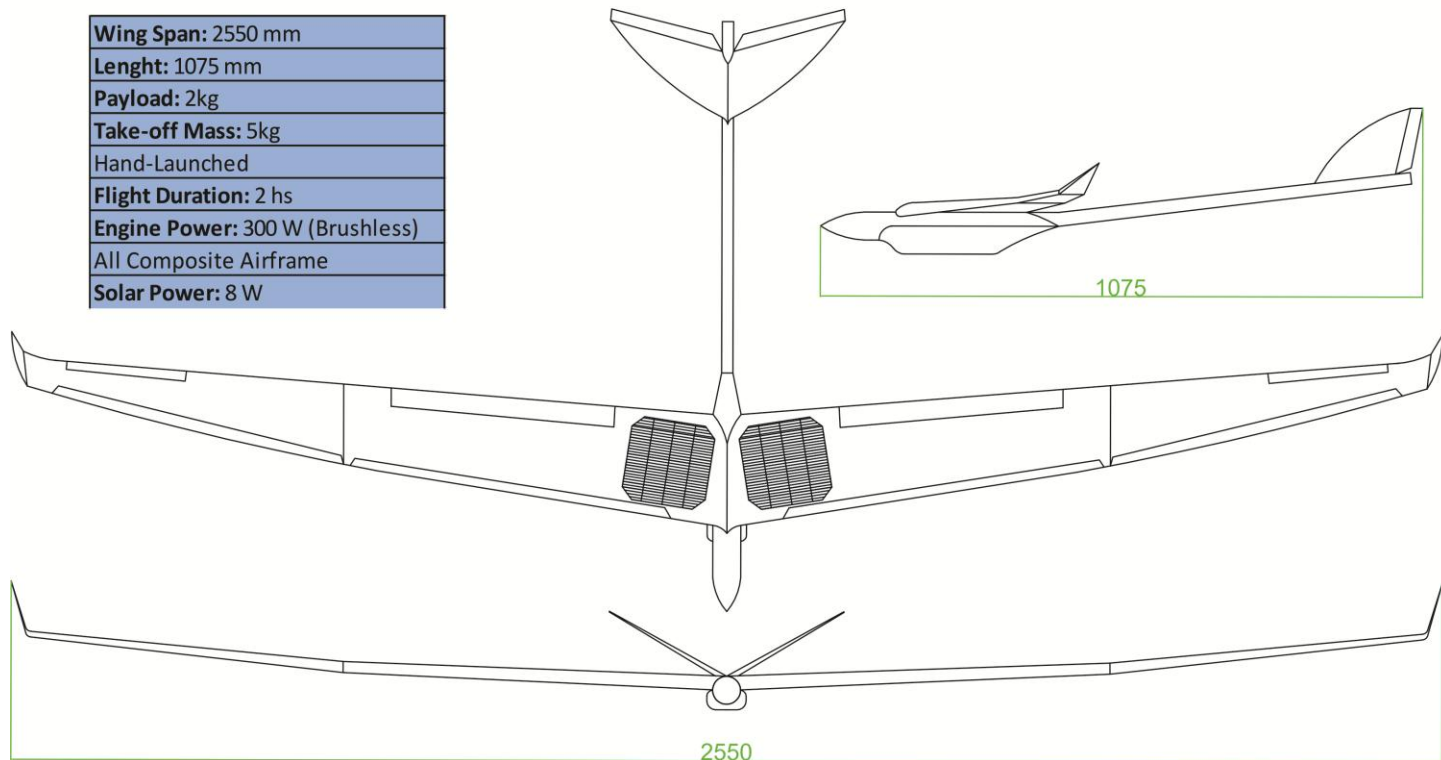



Acrux Aerospace Technologies

ACROVANT VI





Acrux Aerospace Technologies

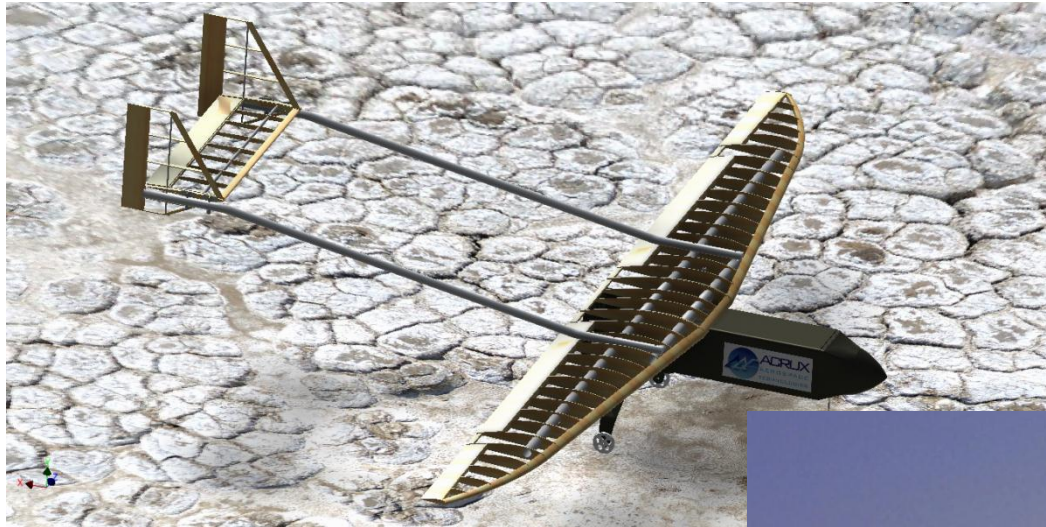

DELTA IV





Acrux Aerospace Technologies

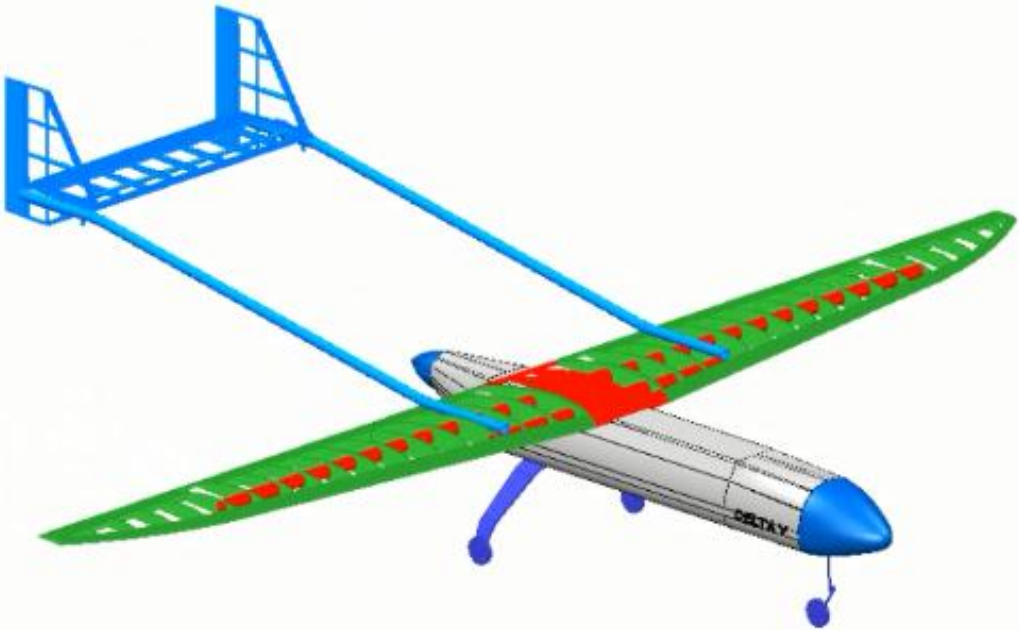

DELTA V





Acrux Education

Encontro Regional de Ensino Astronáutica





AcruX Education

•KIT FOG + KIT CanSat

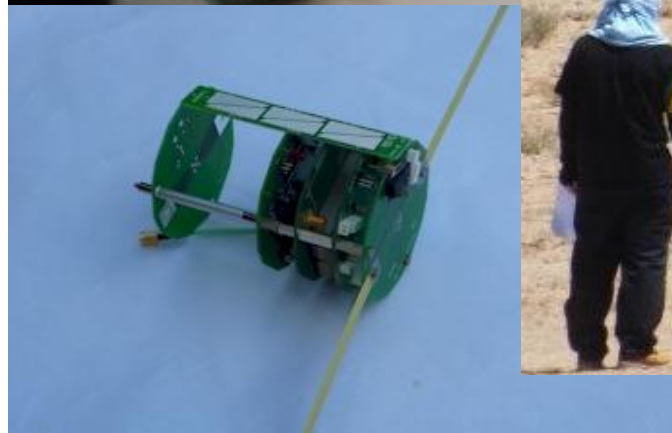



Acrux Education

•BANCADAS & KITs

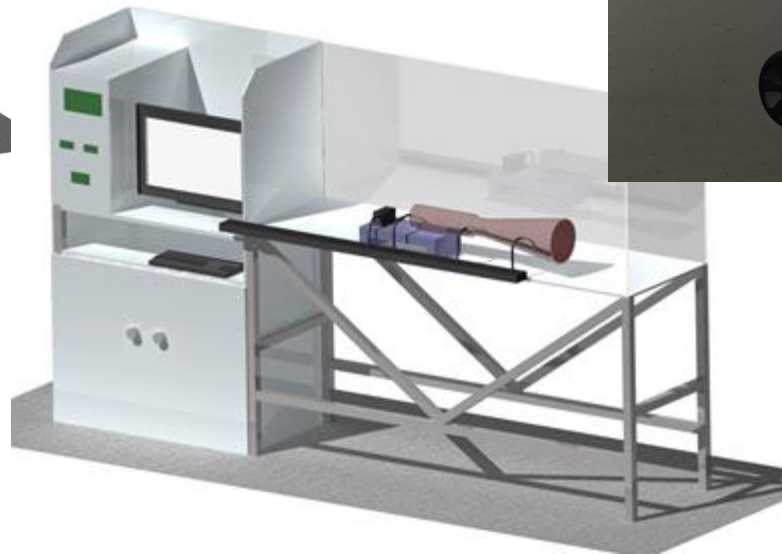
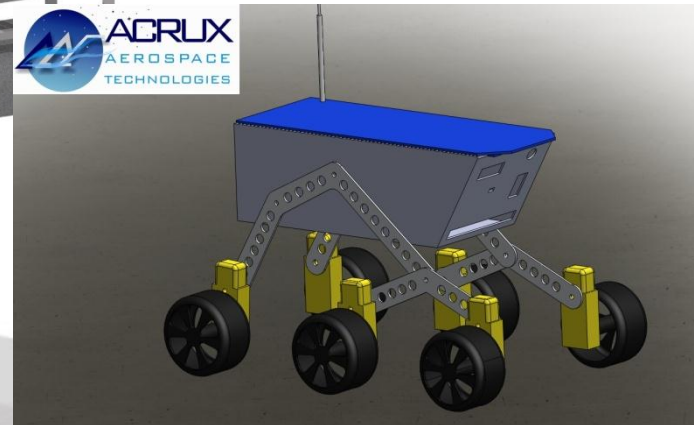
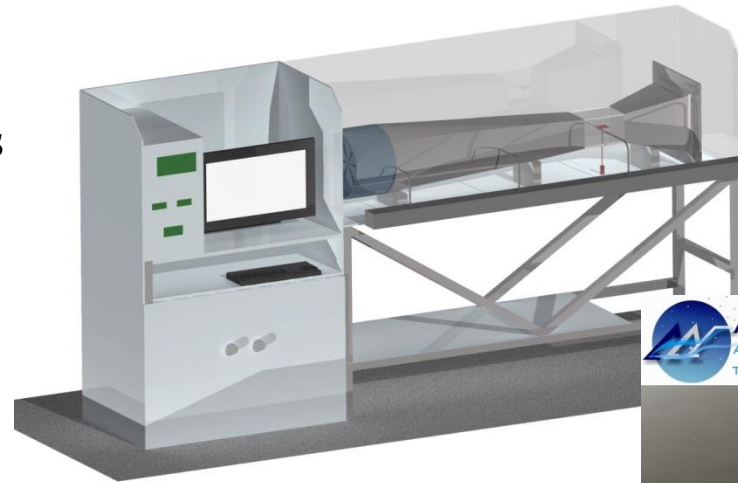
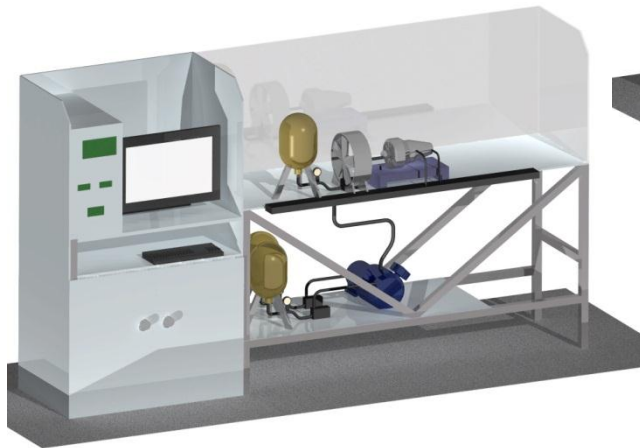



Acrux Aerospace Technologies

- Energia Solar

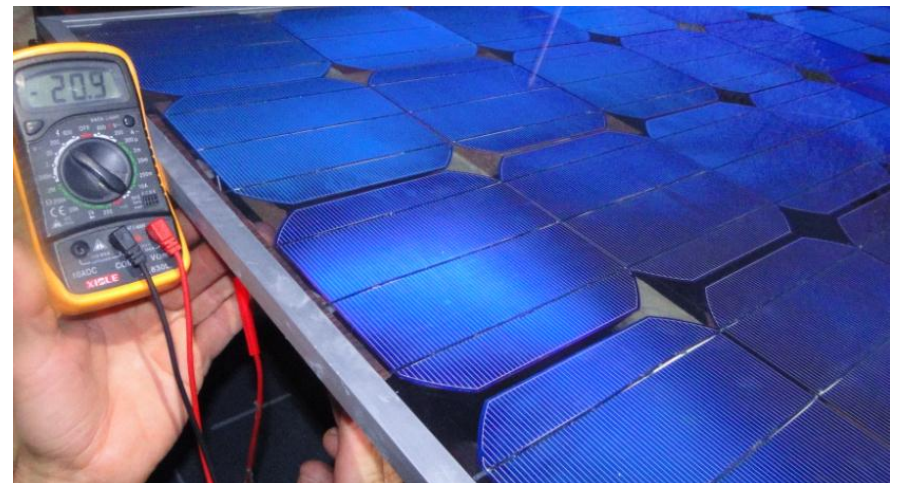
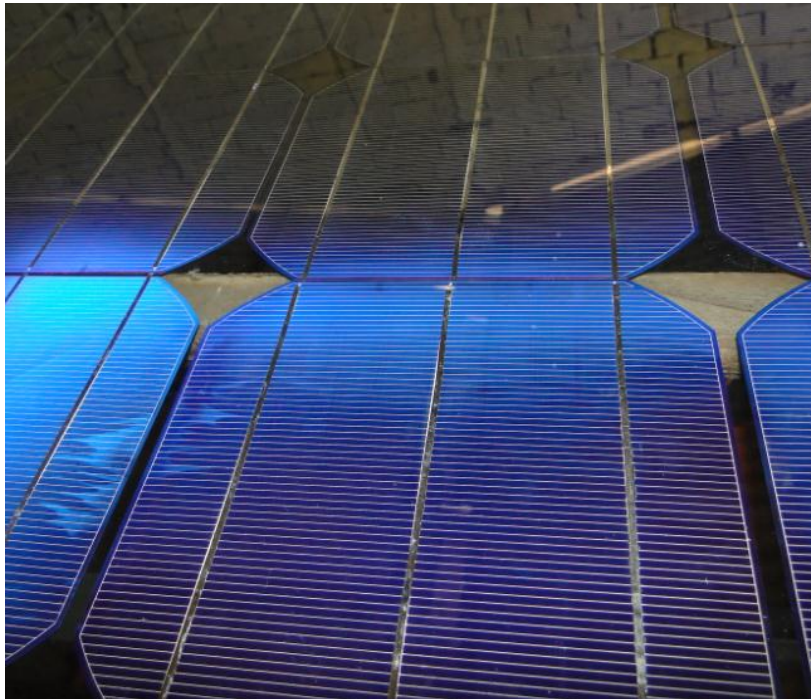
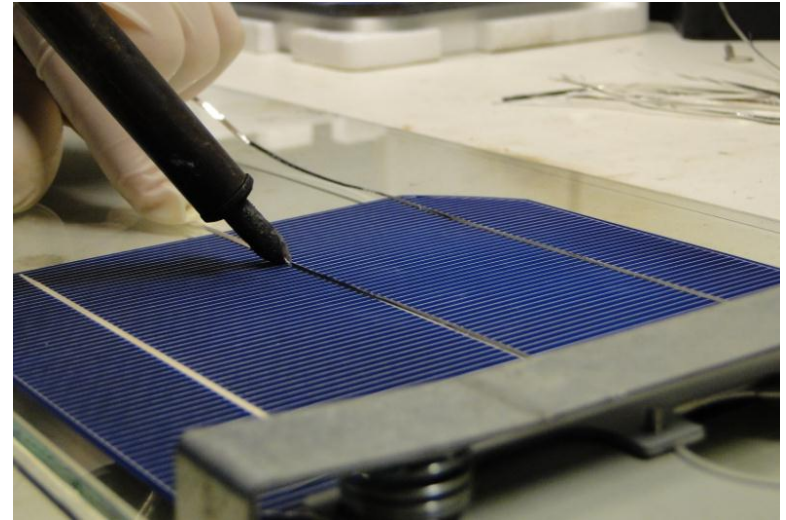



Acrux Aerospace Technologies

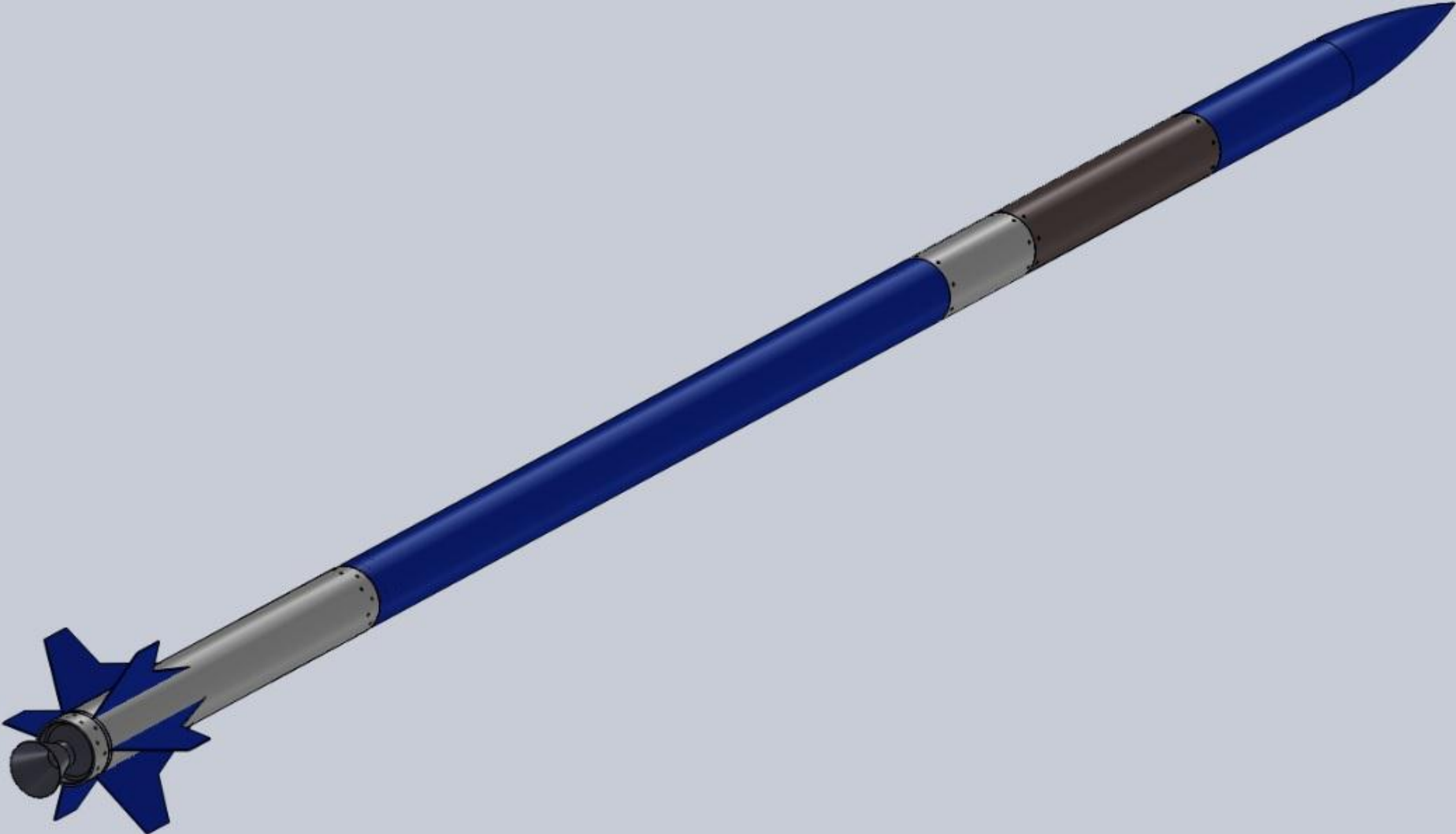

POTENCIAS PARTICIPANTES

- Universidade de Brasília - UnB
- Universidade Federal do ABC - UFABC
- Instituto Tecnológico de Aeronáutica - ITA
- Universidade de São Paulo - EESC/USP
- Universidade Federal do Paraná – UFPR
- Universidade de Campinas - UNICAMP
- Faculdade de Tecnologia de São José dos Campos - FATEC-SJC
- Universidade Federal de Minas Gerais - UFMG
- Universidade Federal de Itajubá - UNIFEI
- Universidade Federal de Mato Grosso do Sul - UFMS
- Universidade Federal de Santa Catarina - UFSC
- Universidade do Vale do Paraíba - UNIVAP
- Universidade Paulistas - UNIP
- Pontificia Universidade Católica de Minas Gerais - PUC Minas
- Universidade Federal de Santa Maria - UFSM
- Acrux Aerospace Technologies
- Edge of Space

POSSÍVEIS FUNDOS DE FINANCIAMENTO

- FAPESP em São Paulo;
- FAPEMIG em Minas Gerais;
- FUNDECT em Mato Grosso do Sul;
- FAPERJ no Rio de Janeiro;
- FAPESC em Santa Catarina;
- Fundação Araucária no Paraná;
- FAPEMA no Maranhão;
- FAPERN no Rio Grande do Norte;
- FAPERGS no Rio Grande do Sul;
- AEB/Programa UNIESPAÇO - Nacional;
- CNPq - Nacional;
- CAPES - Nacional;
- FINEP - Nacional;
- Editais de P&D da ANEEL e ANP.



Acrux Aerospace Technologies

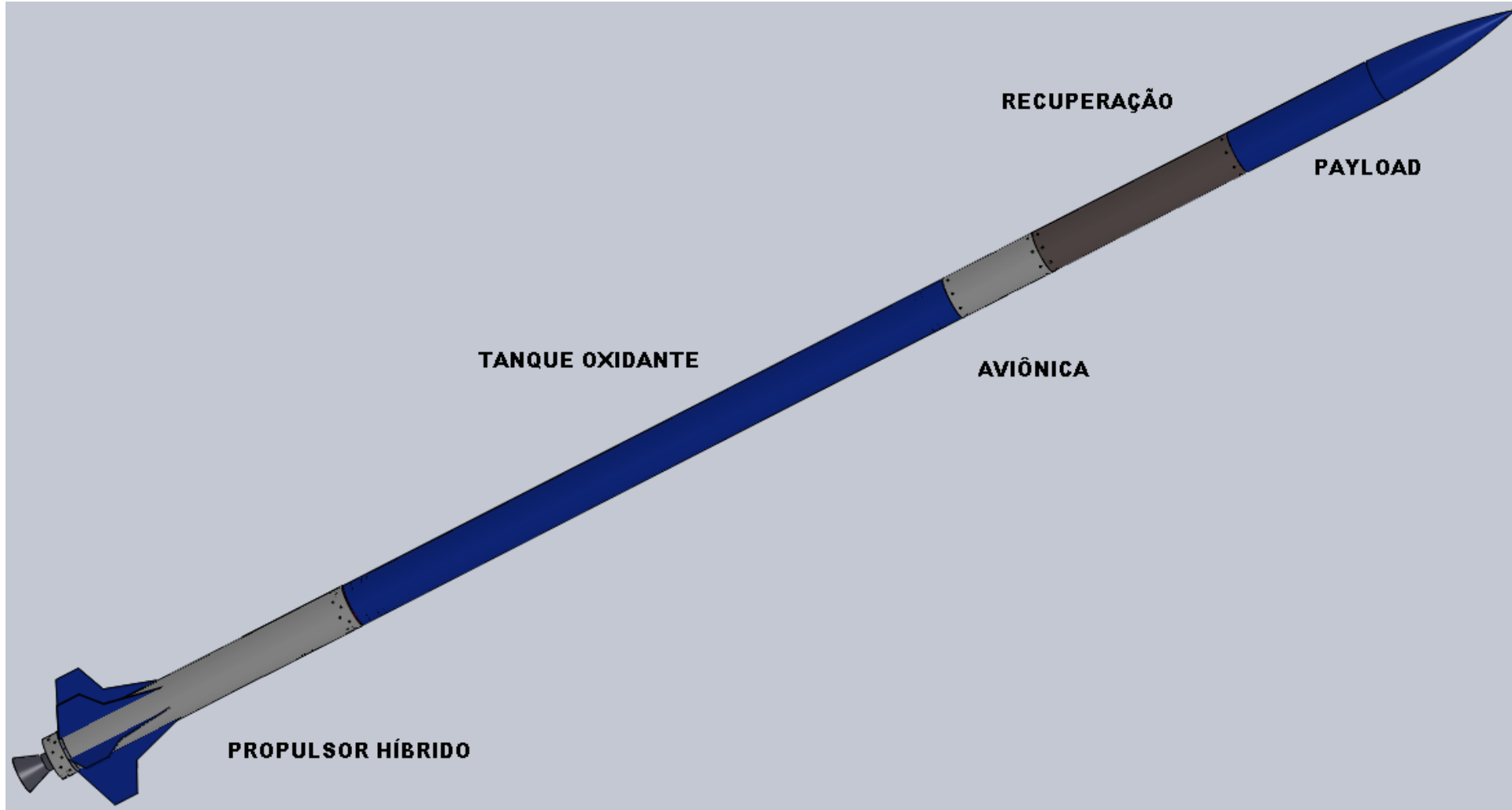



Acrux Aerospace Technologies

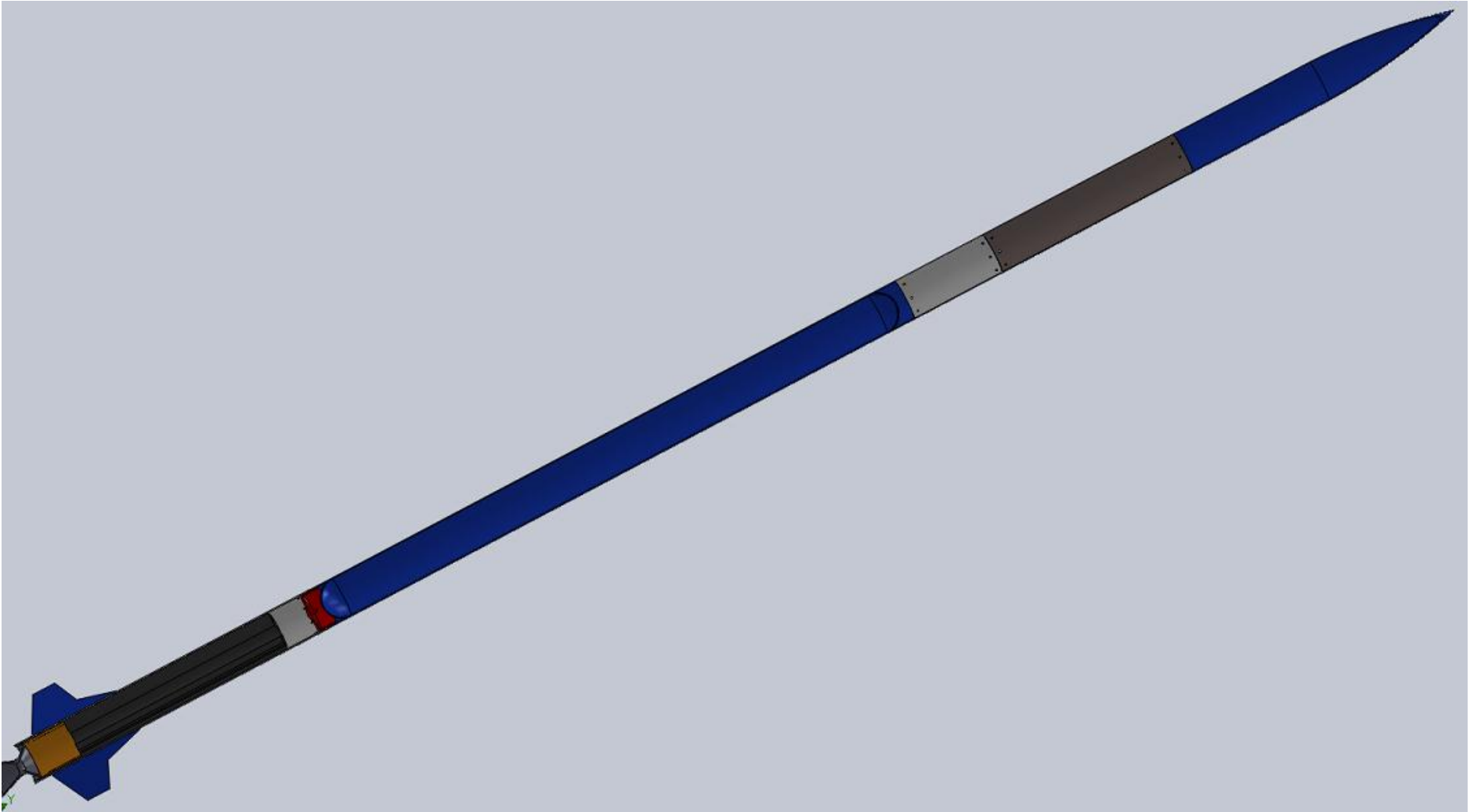



Acrux Aerospace Technologies

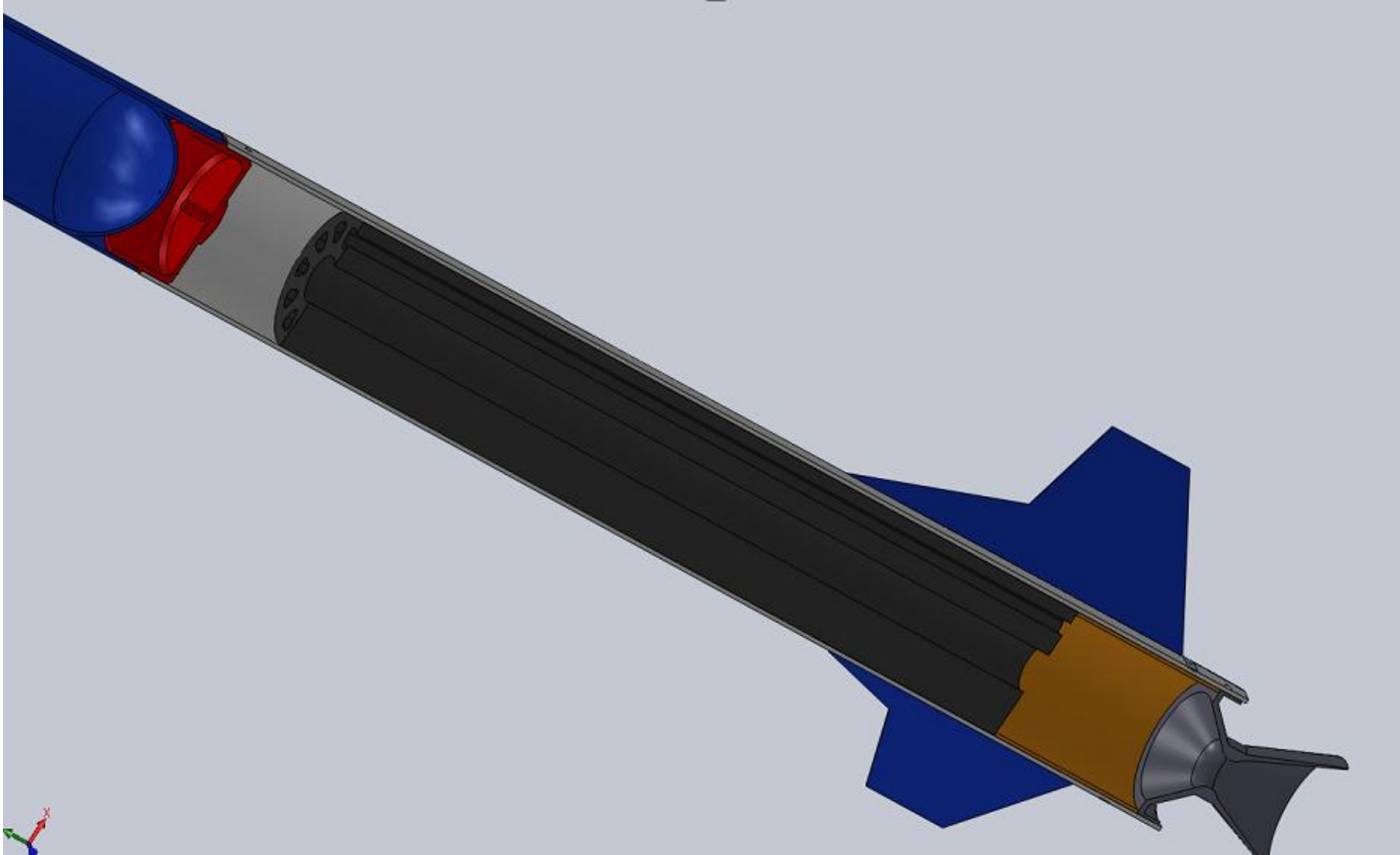



Acrux Aerospace Technologies

Obrigado!

Me. Oswaldo B. Loureda
oswaldobl@gmail.com

www.aatsolutions.net